

**SCALPEL HANDLES**

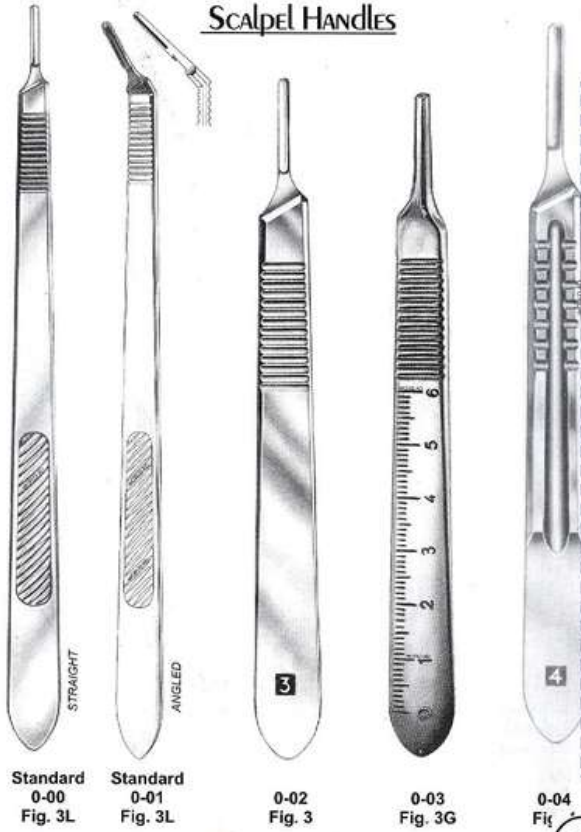

**SCALPEL HANDLES**



1

**DISSECTING KNIVES**

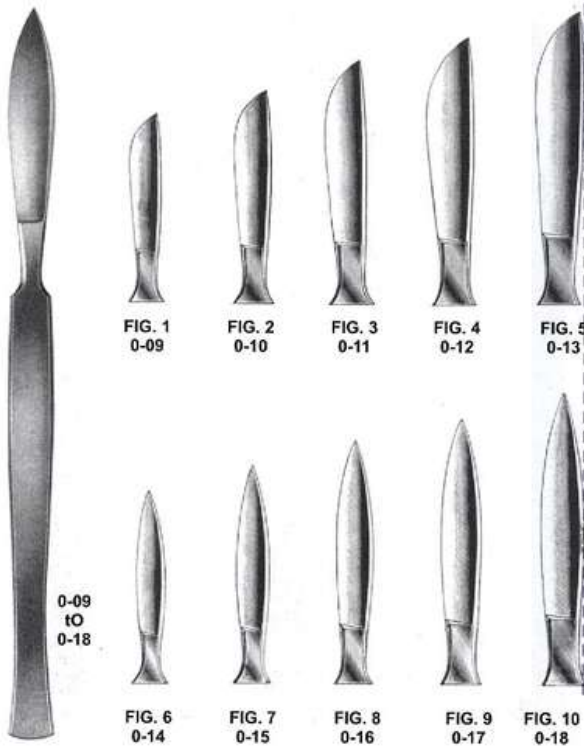

**OPERATING, AMPUTATING KNIVES**

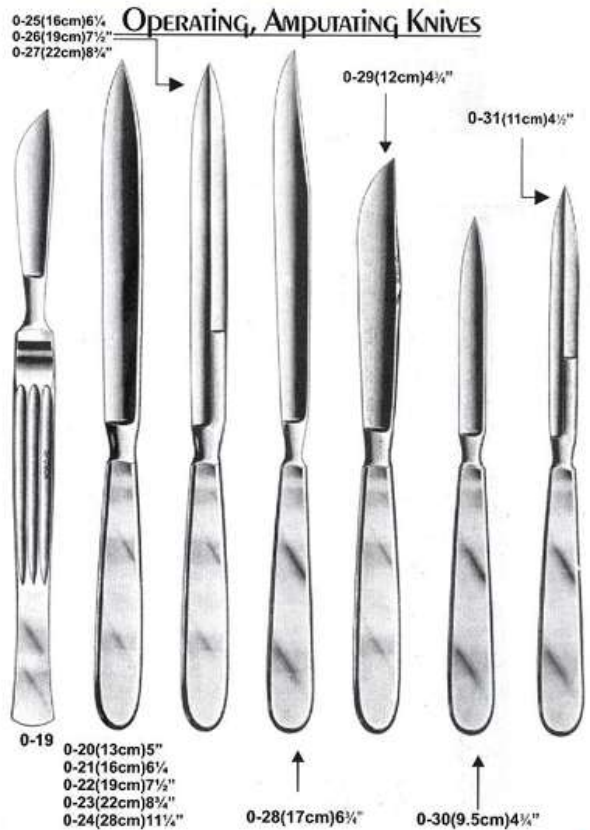

**RESECTION KNIVES**



Langenbeck  
0-32  
(metal handle)

Cartilage knife

0-33

0-34  
with dissector end  
(wooden handle)



**AUTOPSY KNIVES**

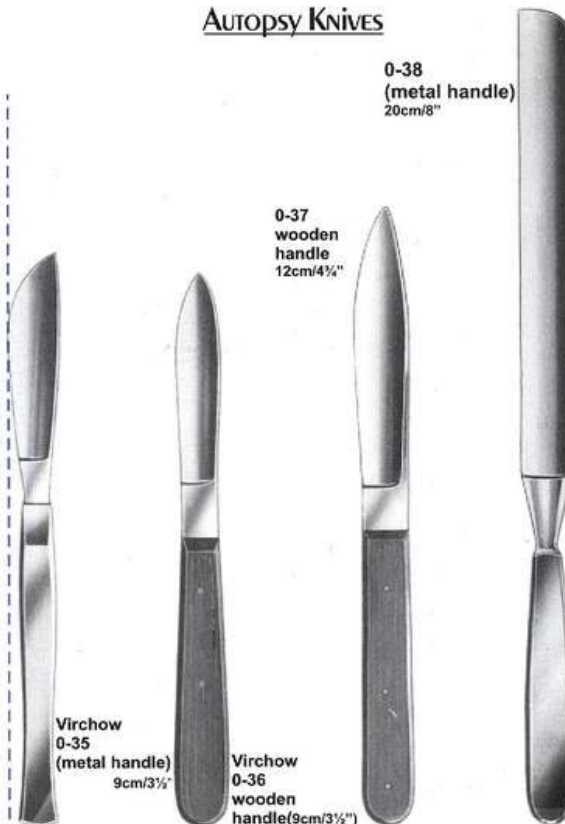

Virchow  
0-35  
(metal handle)  
9cm/3 1/2"

0-37  
wooden  
handle  
12cm/4 1/2"

Virchow  
0-36  
wooden  
handle(9cm/3 1/2")

0-38  
(metal handle)  
20cm/8"

2

**POST MARTEM & BRAIN KNIFE**

Post Martem knife



(wooden handle)  
0-39(11cm)4 1/4"  
0-40(17cm)6 1/4"

Brain knife



Virchow  
(metal handle)  
0-41(16cm)6 1/4"  
0-42(20cm)8"  
0-43(24cm)9 1/2"

**DISSECTING KNIVES**

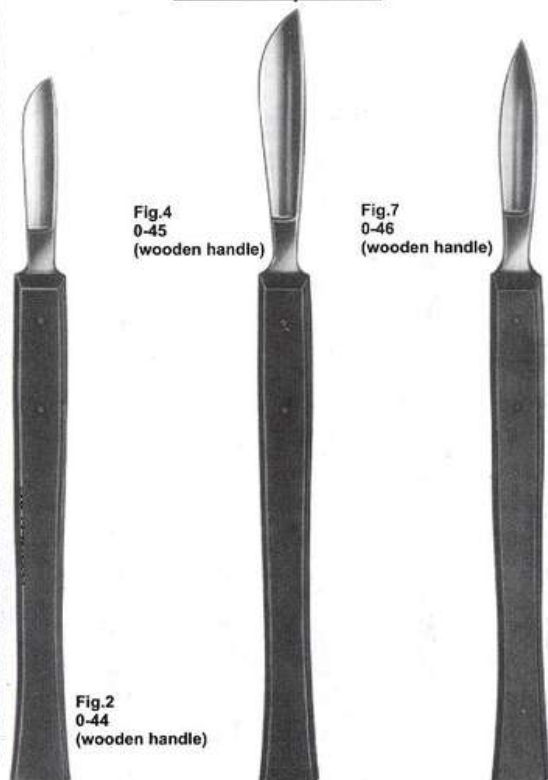

Fig.4  
0-45  
(wooden handle)

Fig.7  
0-46  
(wooden handle)

Fig.2  
0-44  
(wooden handle)

## PLASTER-OF-PARIS KNIVES



## EYE KNIVES



3

## CATARACT, DIACISSION KNIVES, KERATOMES

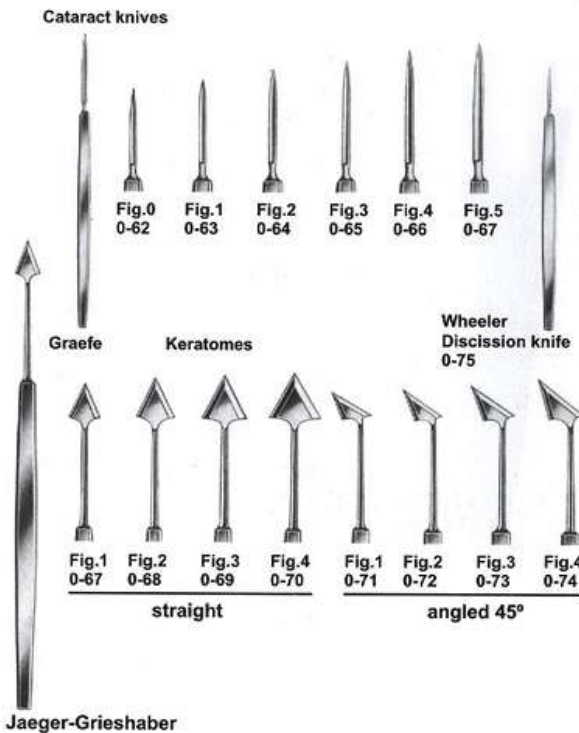

## RHINOPLASTIC KNIVES

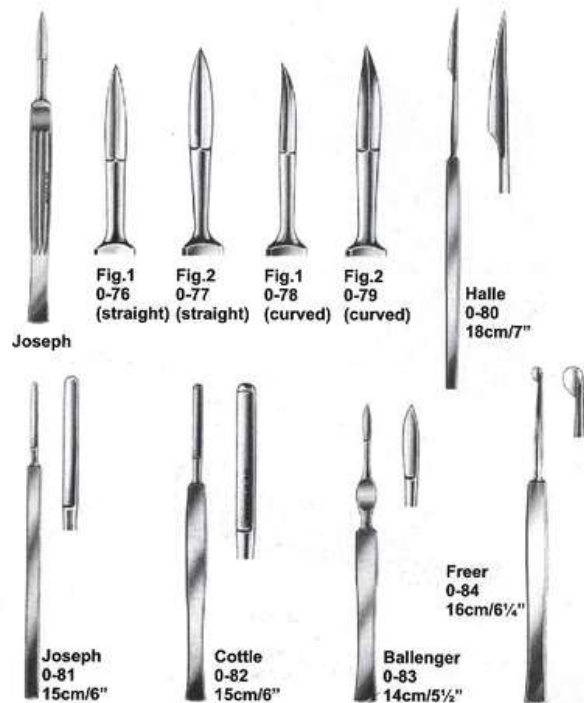



DIAGNOSTICS

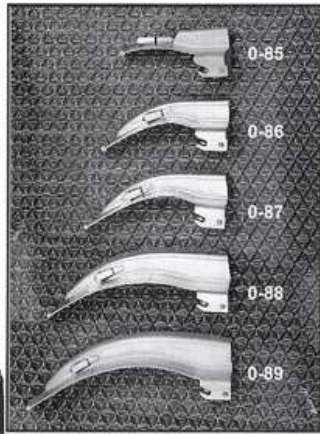

McIntosh



McIntosh  
Laryngoscope Set  
0-90

DIAGNOSTICS

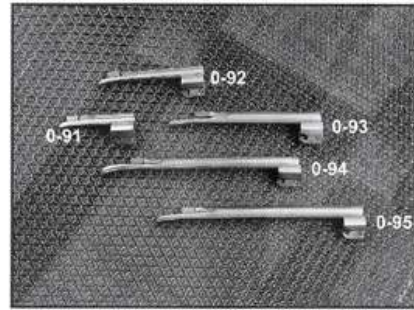

Miller



Miller  
0-96  
Laryngoscope  
set

4

DIAGNOSTICS



Otoscope Set  
0-97  
Consisting Of Battery Handle  
(without Battery) 3 Ear Specula, 1 Bulb

DIAGNOSTICS



Diagnostic Set  
(ENT Complete)  
0-98  
Consisting Of Battery Handle (without Battery)  
3 Ear Specula, 1 Nasal Specula,  
2 Laryngeal Mirrors With Holder  
1 Tongue Depressor Holder, 1 Bulb

## DISSECTING SETS

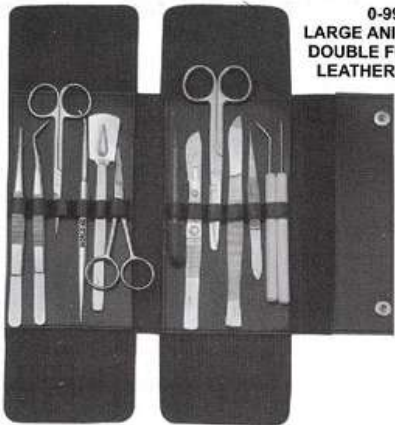

0-99  
LARGE ANIMAL SET  
DOUBLE FOLDING  
LEATHER CASE.



0-100  
GENERAL BIOLOGY  
DISSECTING SET  
SINGLE LEATHER CASE.

## DISSECTING SETS

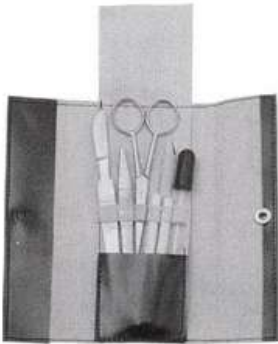

0-103  
BASIC DISSECTING SETS  
VINYLE POUCH.

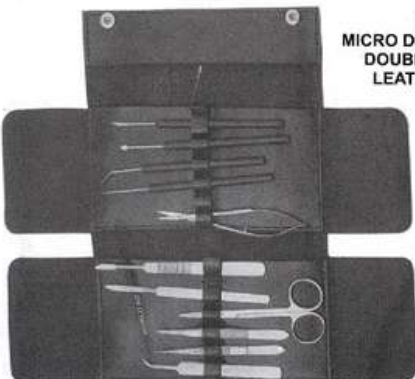

0-104  
MICRO DISSECTING SET  
DOUBLE FOLDING  
LEATHER CASE.

## DISSECTING SETS

0-101  
TISSUE CULTURE  
DISSECTING SET  
LEATHERETTE CASE.

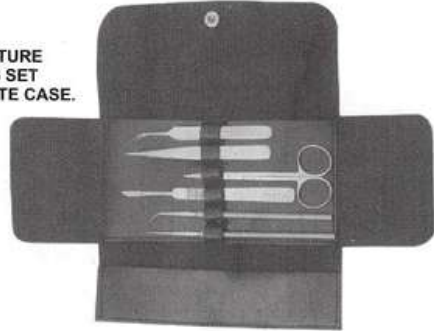

0-102  
ANATOMY DISSECTING SET  
DOUBLE FOLDING  
LEATHER CASE.

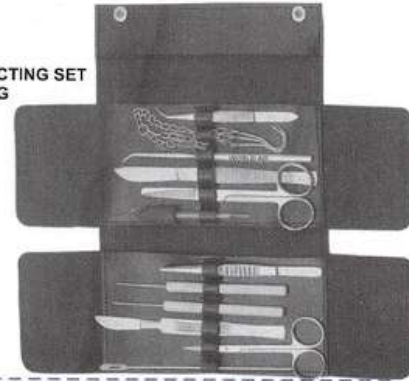

5

## DISSECTING SETS

0-105  
ANATOMY  
DISSECTING SET  
DOUBLE FOLDING  
LEATHER CASE.



0-106  
NEW INSTRUCTOR'S  
DISSECTING SET.  
ZIPPERED CASE

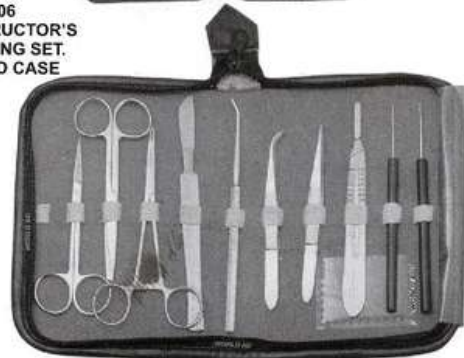

**PERCUSSION HAMMERS**



**PERCUSSION HAMMERS**

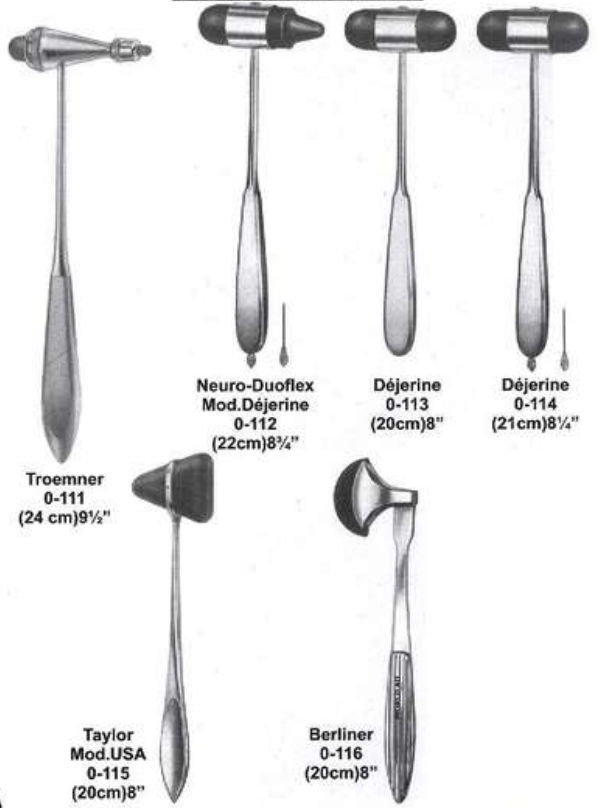

6

**SENSIBILITY INSTRUMENTS**

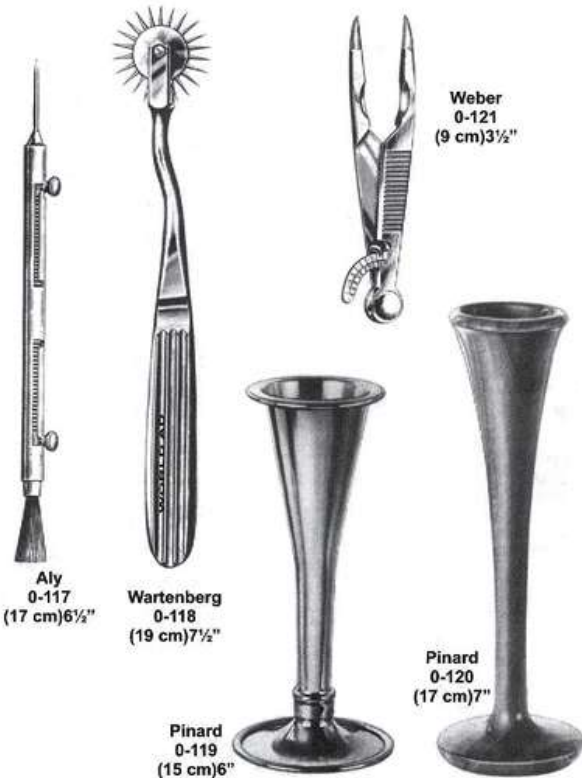

**TUNING FORKS**

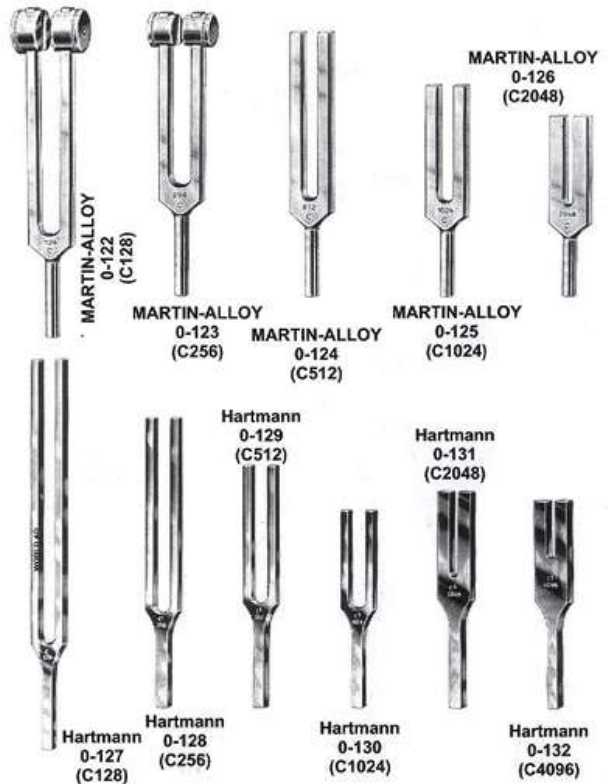



PROBES

PROBES



Stacke  
0-133  
(10.5cm) 4 1/4"  
1 mmØ



0-134(14.5cm) 5 1/2"  
0-135(16cm) 6 1/4"  
0-136(20cm) 8"



0-137(11.5cm) 4 1/2"  
0-138(13cm) 5"  
0-139(14.5cm) 5 1/2"  
0-140(16cm) 6 1/4"  
0-141(18cm) 7"  
0-142(20cm) 8"



0-143(13cm) 5"  
0-144(14.5cm) 5 1/2"  
0-145(16cm) 6 1/4"  
0-146(18cm) 7"



Doyen  
0-147  
(14cm) 5 1/2"  
1 mmØ



Nélaton  
0-148  
(16cm) 6 1/4"  
1 mmØ

7

CURETTES

CURETTES & SPOON



Langenbeck  
0-149  
13cm (5 1/4")



Shapleigh  
13cm (5 1/4")



Buck  
16.5cm (6 1/2")

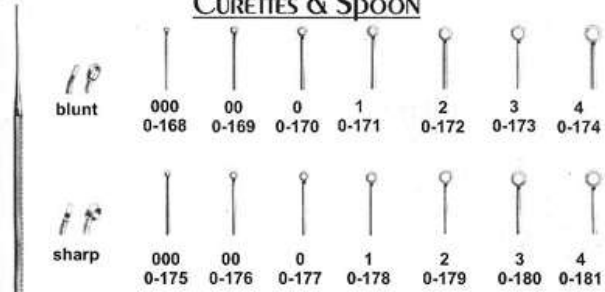
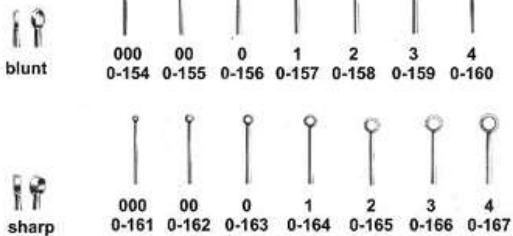

Buck  
16.5cm (6 1/2")



Coxeter  
0-182  
15cm (6")



Mod. Martin  
0-183  
17cm (6 3/4")



Jansen  
0-184  
15cm (6")



Barth  
0-185  
18cm (7 1/4")

### SUCTION TUBES

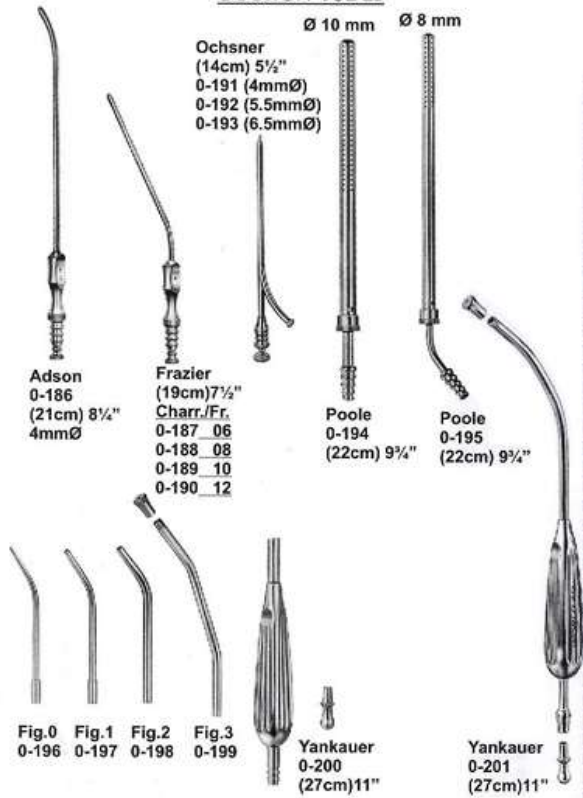

### SUCTION TUBES



### TRACHEA TUBES



8

### CATHETER INTRODUCING FORCEPS





**TROCARS**

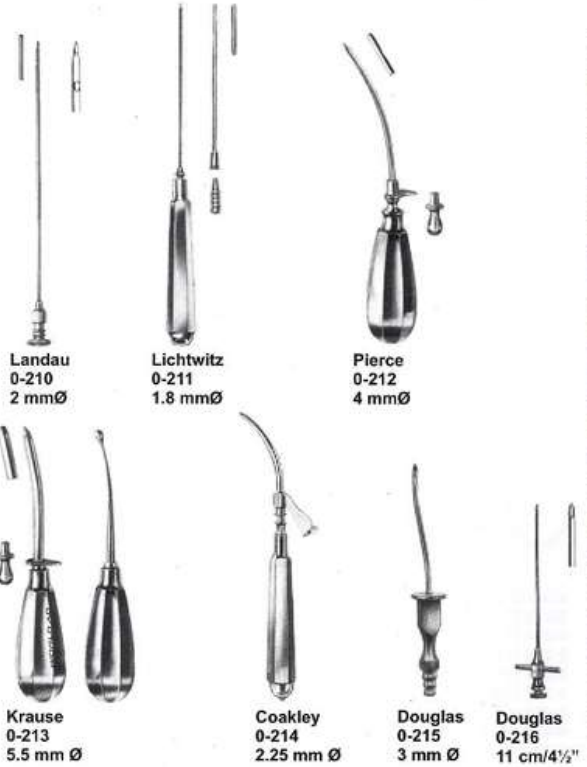

Landau  
0-210  
2 mm Ø

Lichtwitz  
0-211  
1.8 mm Ø

Pierce  
0-212  
4 mm Ø

Krause  
0-213  
5.5 mm Ø

Coakley  
0-214  
2.25 mm Ø

Douglas  
0-215  
3 mm Ø

Douglas  
0-216  
11 cm / 4 1/2"

**TROCARS**

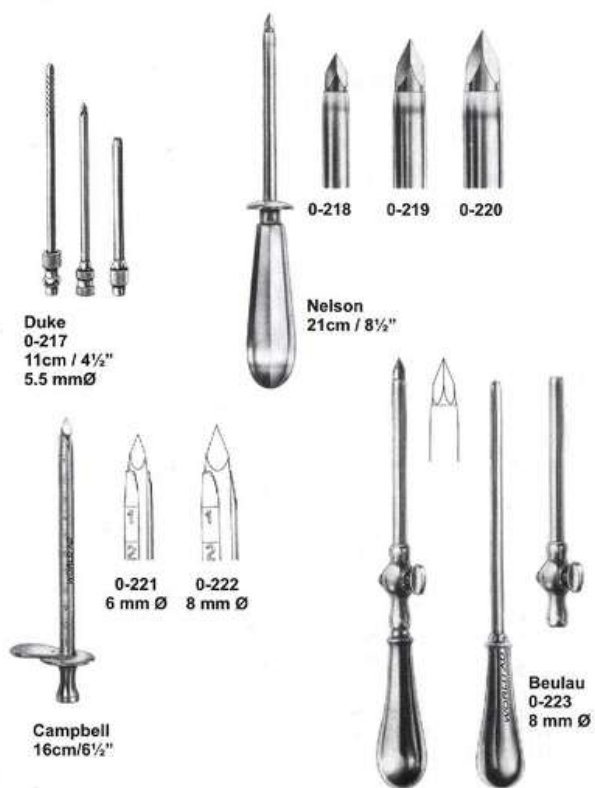

Duke  
0-217  
11cm / 4 1/2"  
5.5 mm Ø

Nelson  
21cm / 8 1/2"

0-218

0-219

0-220

0-221  
6 mm Ø

0-222  
8 mm Ø

Campbell  
16cm / 6 1/2"

Beulau  
0-223  
8 mm Ø

**TROCARS**



Universal  
0-224 (set of 3 pieces)  
0-225 (set of 4 pieces)

Standard  
11 cm / 4 1/2"  
0-226 (3 mm Ø)  
0-227 (4 mm Ø)  
0-228 (5 mm Ø)  
0-229 (6 mm Ø)

Standard  
12 cm / 4 3/4"  
0-230 (3 mm Ø)  
0-231 (4 mm Ø)  
0-232 (5 mm Ø)  
0-233 (6 mm Ø)

Standard  
12 cm / 4 3/4"  
0-234 (3 mm Ø)  
0-235 (4 mm Ø)  
0-236 (5 mm Ø)  
0-237 (6 mm Ø)

**TROCARS**

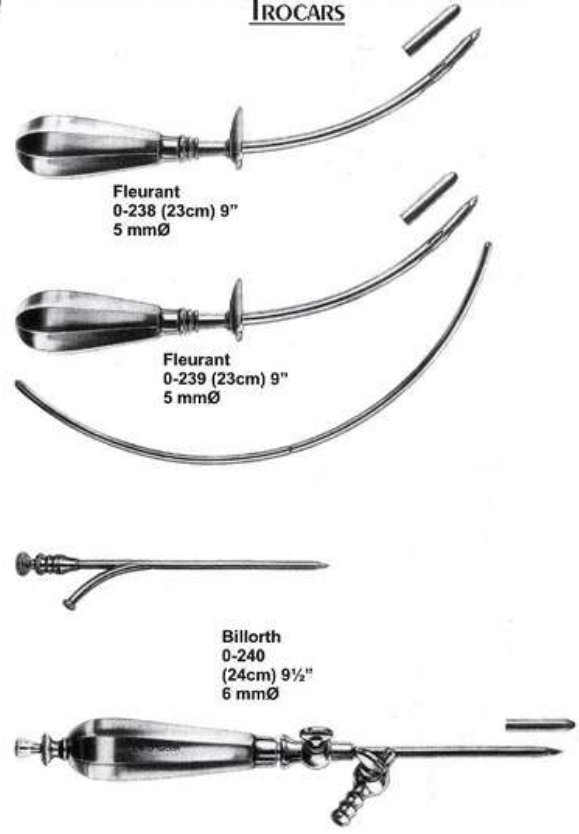

Fleurant  
0-238 (23cm) 9"  
5 mm Ø

Fleurant  
0-239 (23cm) 9"  
5 mm Ø

Billorth  
0-240  
(24cm) 9 1/2"  
6 mm Ø

OPERATING SCISSORS

Straight



Straight



Straight



**STANDARD**  
 0-241 (10.5cm) 4 1/4 " "  
 0-242 (11.5cm) 4 1/2 " "  
 0-243 (13...cm) 05 " "  
 0-244 (14.5cm) 5 1/4 " "  
 0-245 (15.5cm) 06 " "  
 0-246 (16.5cm) 6 1/2 " "  
 0-247 (17.5cm) 07 " "  
 0-248 (18.5cm) 7 1/4 " "  
 0-249 (20cm...) 08 " "

**STANDARD**  
 0-250 (10.5cm) 4 1/4 " "  
 0-251 (11.5cm) 4 1/2 " "  
 0-252 (13 cm) 05 " "  
 0-253 (14.5cm) 5 1/4 " "  
 0-254 (15.5cm) 06 " "  
 0-255 (16.5cm) 6 1/2 " "  
 0-256 (17.5cm) 07 " "  
 0-257 (18.5cm) 7 1/4 " "  
 0-258 (20 cm) 08 " "

**STANDARD**  
 0-259 (10.5cm) 4 1/4 " "  
 0-260 (11.5cm) 4 1/2 " "  
 0-261 (13...cm) 05 " "  
 0-262 (14.5cm) 5 1/4 " "  
 0-263 (15.5cm) 06 " "  
 0-264 (16.5cm) 6 1/2 " "  
 0-265 (17.5cm) 07 " "  
 0-266 (18.5cm) 7 1/4 " "  
 0-267 (20cm...) 08 " "

OPERATING SCISSORS

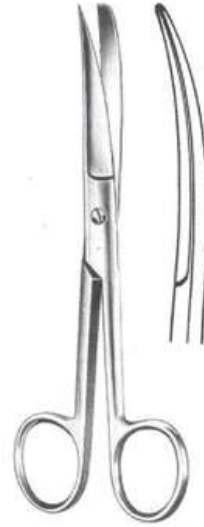

**STANDARD**  
 0-268 (10.5cm) 4 1/4 " "  
 0-269 (11.5cm) 4 1/2 " "  
 0-270 (13...cm) 05 " "  
 0-271 (14.5cm) 5 1/4 " "  
 0-272 (15.5cm) 06 " "  
 0-273 (16.5cm) 6 1/2 " "  
 0-274 (17.5cm) 07 " "  
 0-275 (18.5cm) 7 1/4 " "  
 0-276 (20cm...) 08 " "

**STANDARD**  
 0-277 (10.5cm) 4 1/4 " "  
 0-278 (11.5cm) 4 1/2 " "  
 0-279 (13...cm) 05 " "  
 0-280 (14.5cm) 5 1/4 " "  
 0-281 (15.5cm) 06 " "  
 0-282 (16.5cm) 6 1/2 " "  
 0-283 (17.5cm) 07 " "  
 0-284 (18.5cm) 7 1/4 " "  
 0-285 (20cm...) 08 " "

**STANDARD**  
 0-286 (10.5cm) 4 1/4 " "  
 0-287 (11.5cm) 4 1/2 " "  
 0-288 (13...cm) 05 " "  
 0-289 (14.5cm) 5 1/4 " "  
 0-290 (15.5cm) 06 " "  
 0-291 (16.5cm) 6 1/2 " "  
 0-292 (17.5cm) 07 " "  
 0-293 (18.5cm) 7 1/4 " "  
 0-294 (20cm...) 08 " "

10

OPERATING SCISSORS



**Incision Scissor**  
 0-295 (13cm) 05 " "  
 0-296 (14.5cm) 5 1/4 " "



**Deaver straight**  
 0-297 (14cm) 5 1/2 " "



**Deaver curved**  
 0-298 (14cm) 5 1/2 " "



**Mayo-Still straight**  
 0-299 (15cm) 06 " "  
 0-300 (17cm) 6 1/4 " "  
 0-301 (19cm) 7 1/2 " "



**Mayo-Still curved**  
 0-302 (15cm) 06 " "  
 0-303 (17cm) 6 1/4 " "  
 0-304 (19cm) 7 1/2 " "



**Mayo (straight)**  
 0-305 (14.5cm) 5 1/4 " "  
 0-306 (15cm) 06 " "  
 0-307 (17cm) 6 1/4 " "  
 0-308 (23cm) 09 " "



**Mayo (curved)**  
 0-309 (15cm) 06 " "  
 0-310 (17cm) 6 1/4 " "  
 0-311 (19cm) 7 1/2 " "  
 0-312 (19cm) 7 1/2 " "

## OPERATING SCISSORS

Gynecological Scissor

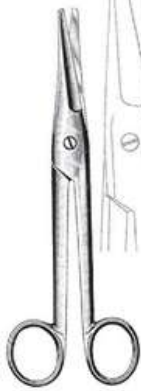

**Mayo-Noble (straight)**  
0-313 (17cm) 6 1/4 inch (curved)  
0-314 (17cm) 6 1/4 inch

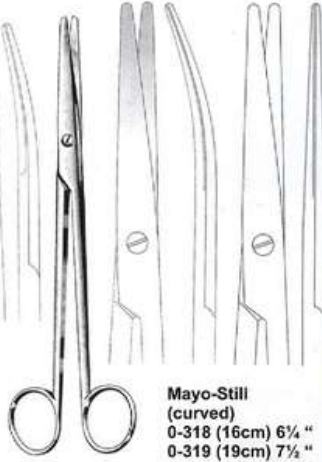

**Mayo-Still (straight)**  
0-315 (16cm) 6 1/4 "  
0-316 (19cm) 7 1/2 "  
0-317 (21cm) 8 1/4 "

**Mayo-Still (curved)**  
0-318 (16cm) 6 1/4 "  
0-319 (19cm) 7 1/2 "  
0-320 (21cm) 8 1/4 "

## OPERATING SCISSORS

Gynecological Scissor



**Wertheim (curved)**  
0-321 (14cm) 5 1/2 "  
0-322 (19cm) 7 1/2 "  
0-323 (22cm) 8 3/4 "

**Mayo-Harrington (straight)**  
0-324 (22cm) 8 3/4 "  
(curved)  
0-325 (22cm) 8 3/4 "  
0-326 (30cm) 12 "

11

## DISECTING SCISSORS

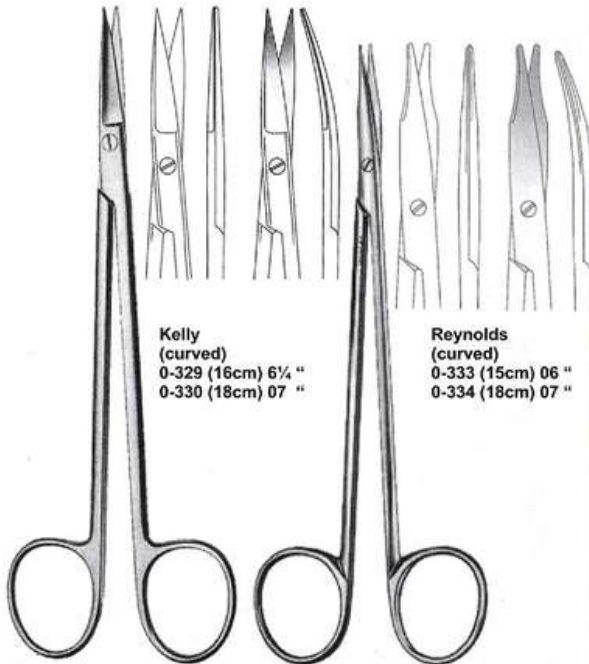

**Kelly (curved)**  
0-329 (16cm) 6 1/4 "  
0-330 (18cm) 07 "

**Reynolds (curved)**  
0-333 (15cm) 06 "  
0-334 (18cm) 07 "

**Kelly (straight)**  
0-327 (16cm) 6 1/4 "  
0-328 (18cm) 07 "

**Reynolds (straight)**  
0-331 (15cm) 06 "  
0-332 (18cm) 07 "

## DISECTING SCISSORS



**Metzenbaum (straight)**  
0-335 (14.5cm) 5 1/4 "

**Metzenbaum-Delikat (straight)**  
0-337 (14.5cm) 5 1/4 "

**Metzenbaum (curved)**  
0-336 (14.5cm) 5 1/4 "

**Metzenbaum-Delikat (curved)**  
0-338 (14.5cm) 5 1/4 "



**DISECTING SCISSORS**



**OPERATING SCISSORS**

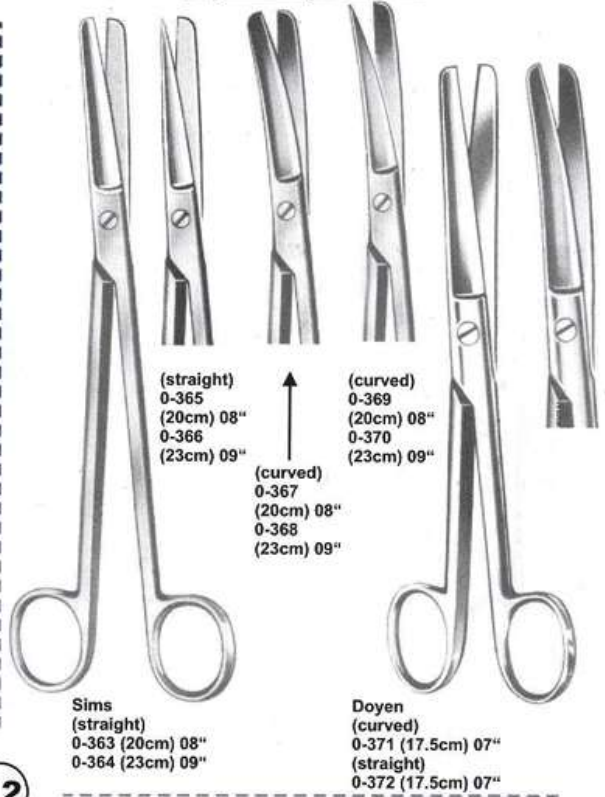

**NEUROSURGICAL SCISSORS**



**NASAL SCISSORS**



EYE SCISSORS

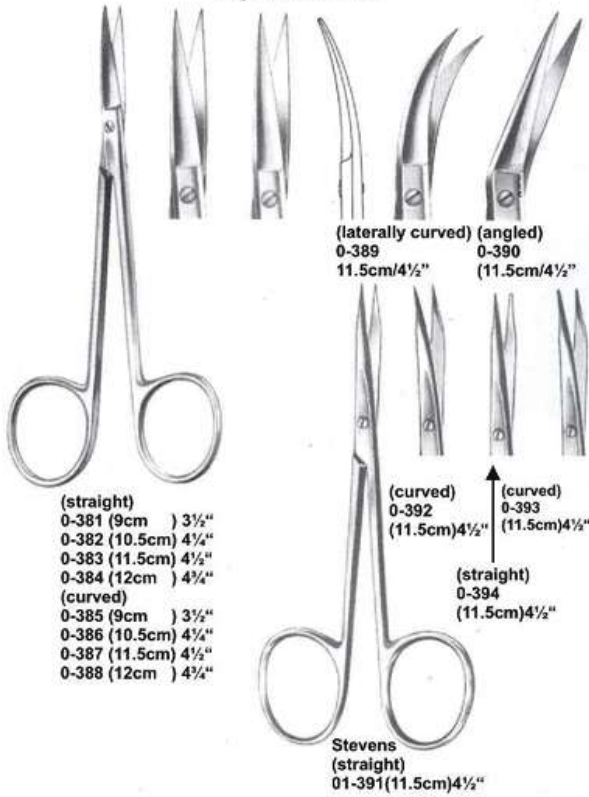

EYE SCISSORS

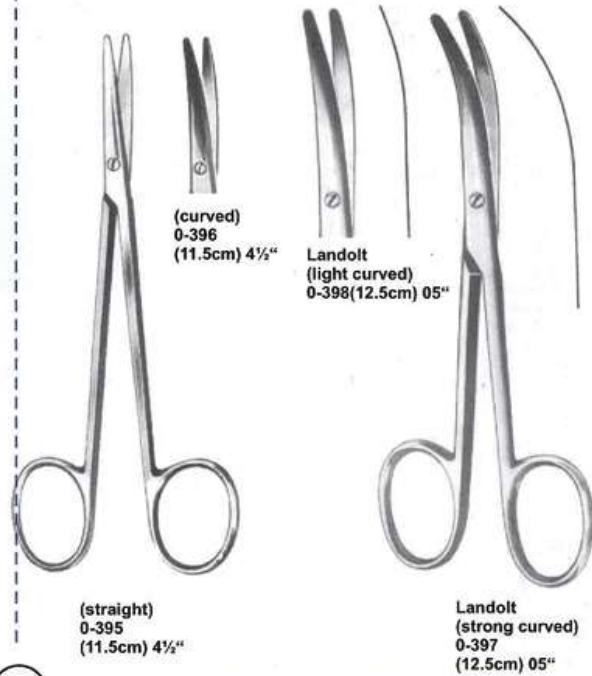

13

ENT SCISSORS



TONSIL SCISSORS

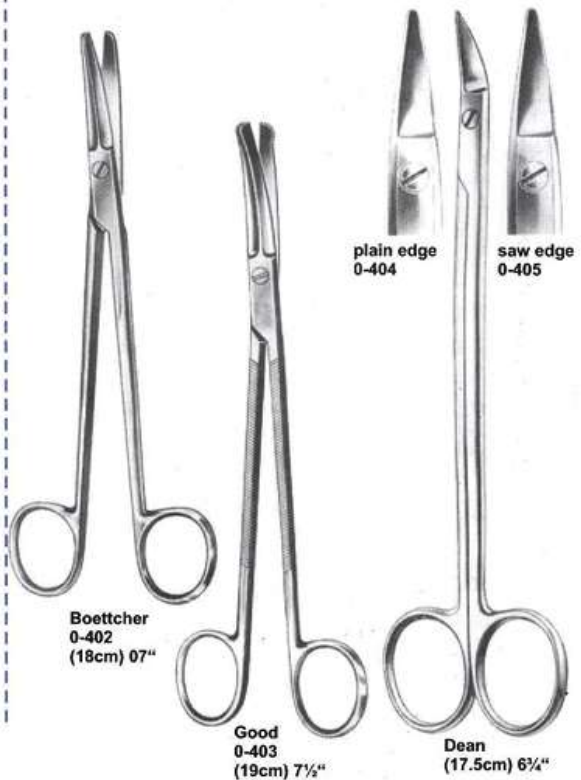

LIGATURE/DISSECTING SCISSORS

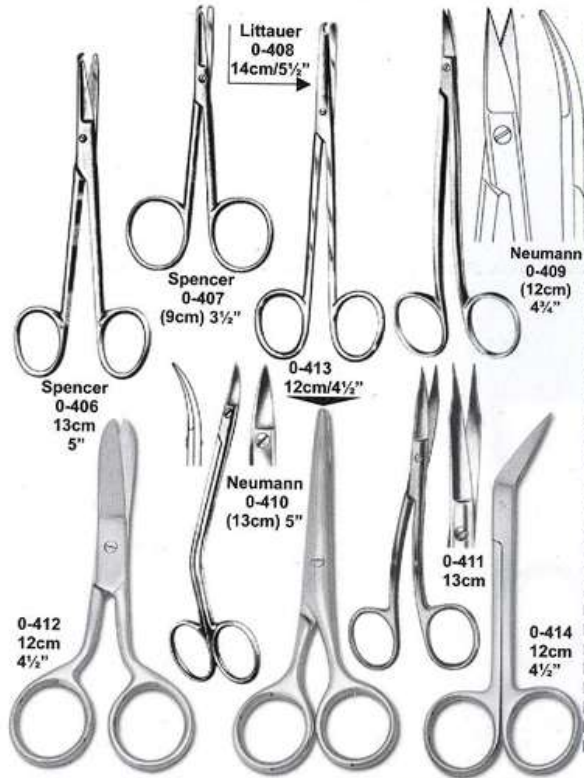

Umbilical Scissors



14

OPERATING SCISSORS

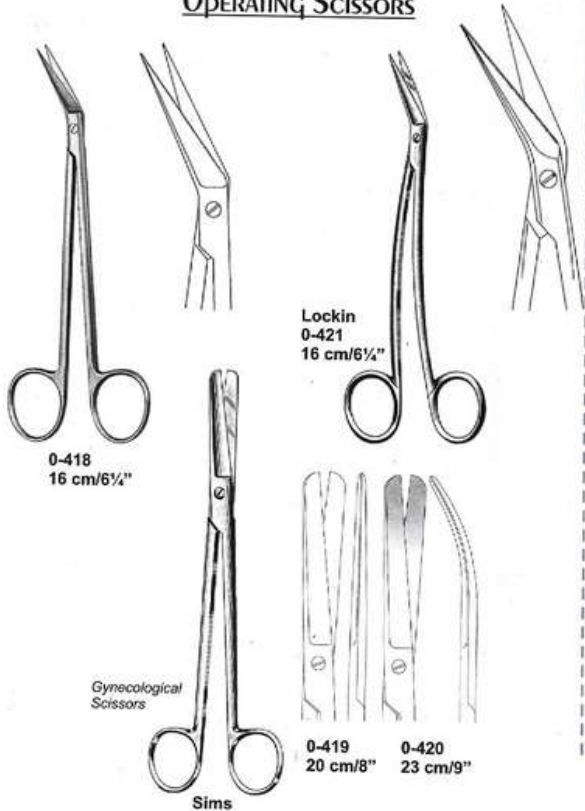

WIRE CUTTING, GUM SCISSORS

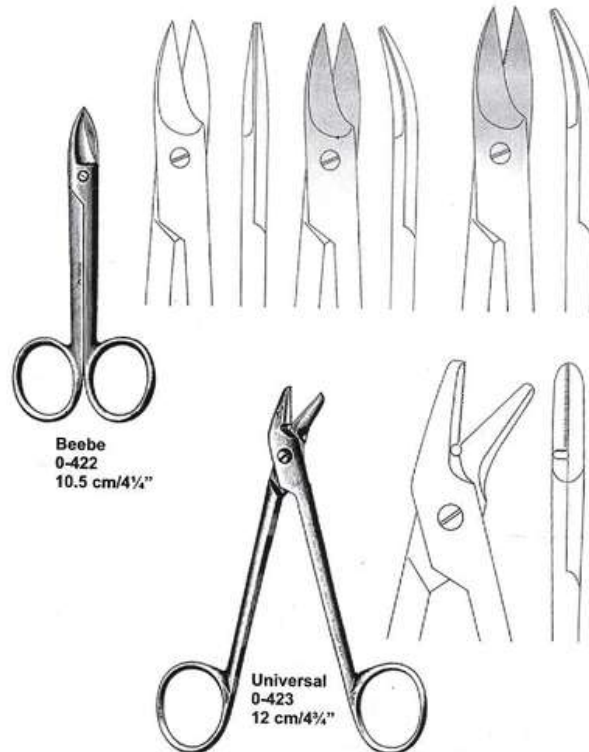



## DRESSING FORCEPS

### Standard

0-424 10.5cm/4 1/4"	0-425 11.5cm/4 1/2"	0-426 13cm/5"	0-427 14.5cm/5 1/4"	0-428 15cm/6"
0-429 16cm/6 1/4"	0-430 18cm/7"	0-431 20cm/8"	0-432 25cm/10"	0-433 30cm/12"

0-434 10.5cm/4 1/4"	0-435 11.5cm/4 1/2"	0-436 13cm/5"	0-437 14.5cm/5 1/4"	<b>Slender</b>
0-438 16cm/6 1/4"	0-439 18cm/7"	0-440 20cm/8"	0-441 25cm/10"	
0-442 30cm/12"				

0-443 10.5cm/4 1/4"	0-444 11.5cm/4 1/2"	0-445 13cm/5"	0-446 14.5cm/5 1/4"	<b>Slender</b>
0-447 16cm/6 1/4"	0-448 18cm/7"	0-449 20cm/8"	0-450 25cm/10"	
0-451 30cm/12"				

0-452 13cm/5"	0-453 14.5cm/5 1/4"	<b>delicate</b>

0-454 13cm/5"	0-455 14.5cm/5 1/4"	<b>delicate</b>

<b>with pin</b>		<b>delicate</b>
0-456 13cm/5"	0-457 14.5cm/5 1/4"	

## DRESSING FORCEPS

### McIndoe

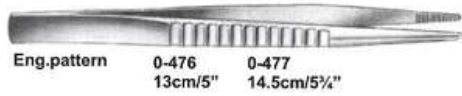

## DRESSING FORCEPS

### Standard Mod.USA

0-458 12cm/4 1/4"	0-459 13cm/5"	0-460 14.5cm/5 1/4"	0-461 15.5cm/6"
0-462 18cm/7"	0-463 20cm/8"	0-464 25cm/10"	0-465 30cm/12"

0-466 12cm/4 1/4"	0-467 13cm/5"	0-468 14.5cm/5 1/4"	0-469 15.5cm/6"	<b>Slender Mod.USA</b>

### Adson



### Micro Adson



15

## DRESSING FORCEPS

### Gerald

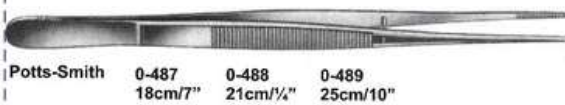

### DRESSING FORCEPS

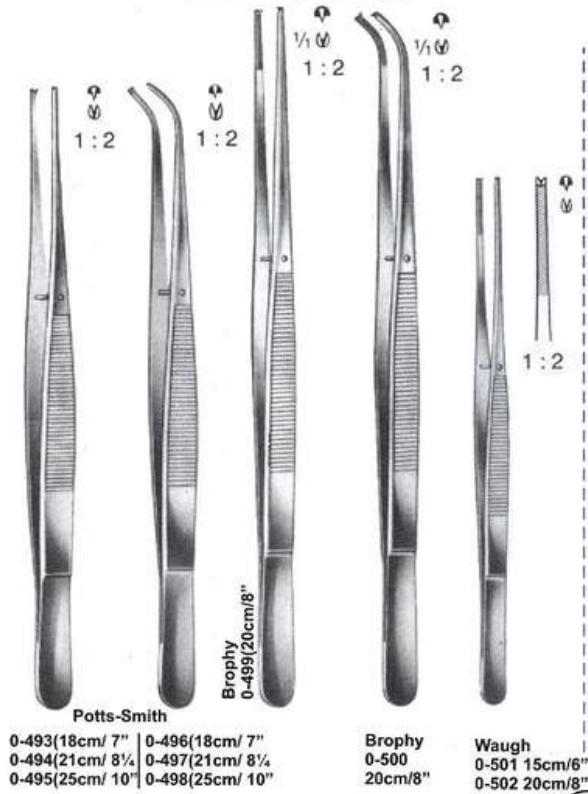

### DRESSING FORCEPS

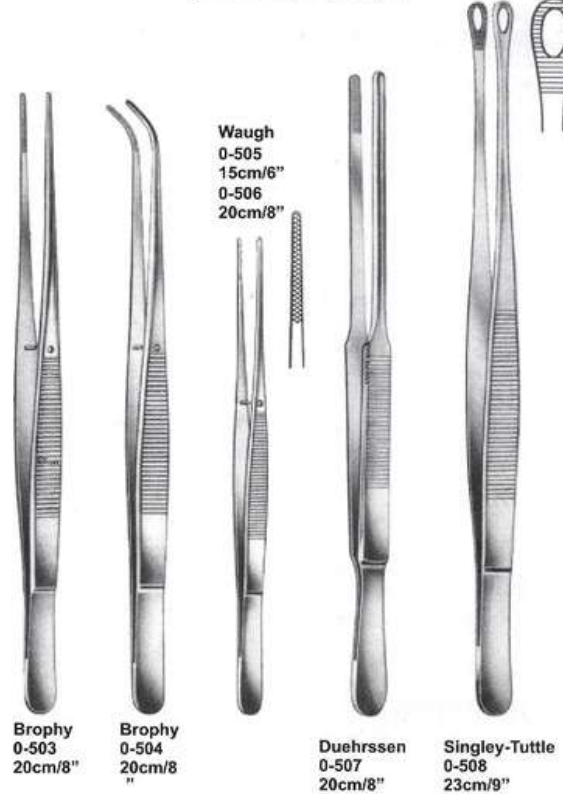

16

### TISSUE FORCEPS

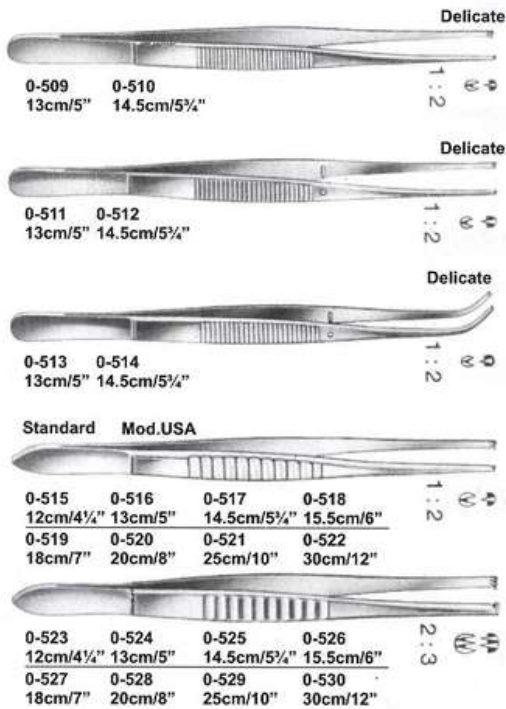

### TISSUE FORCEPS

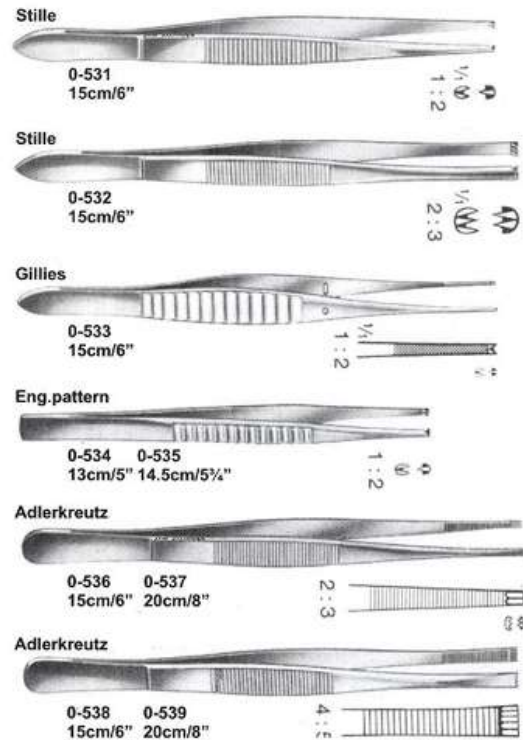

### TISSUE FORCEPS



### TISSUE FORCEPS

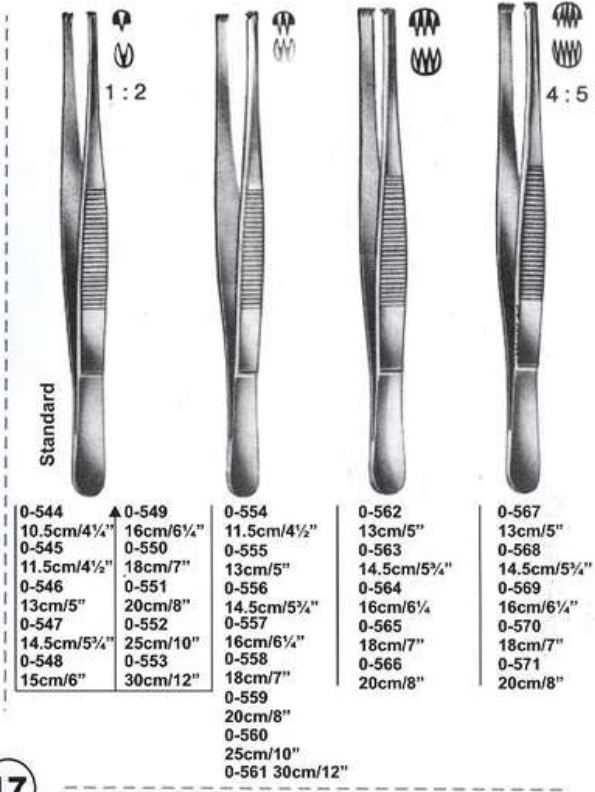

### TISSUE FORCEPS

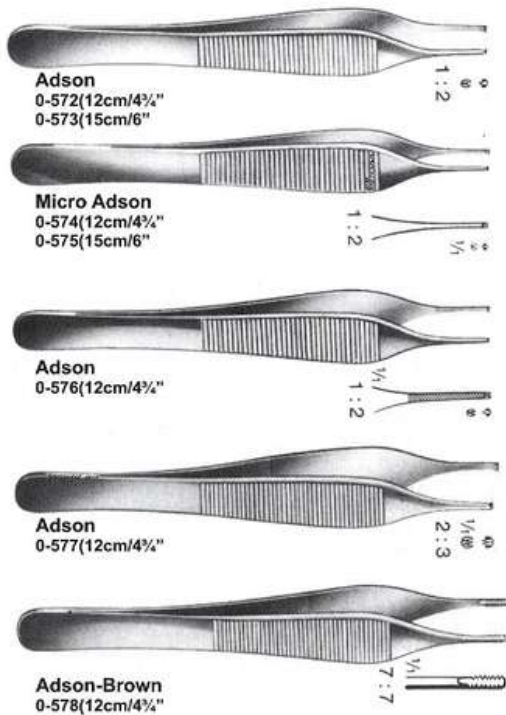

### TISSUE FORCEPS

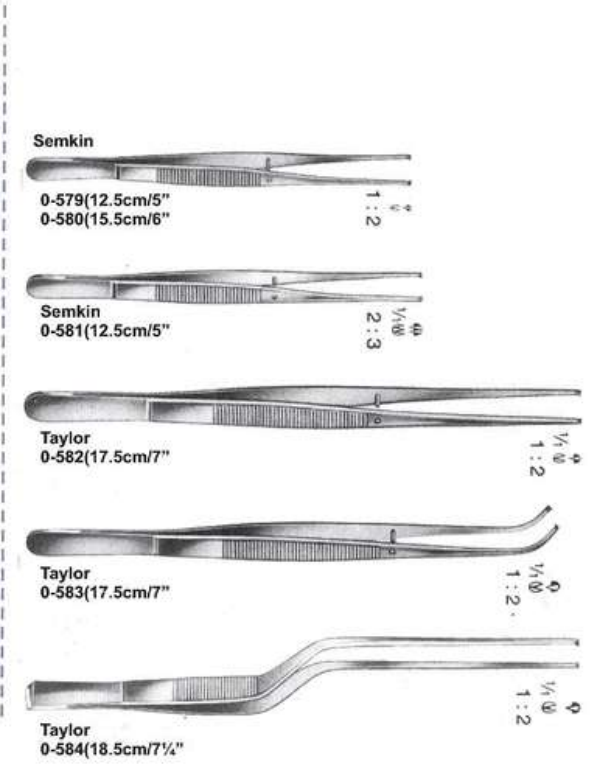



**TISSUE FORCEPS**

**Bonney**  
0-585(18cm/7")  
1:2



**Bonney**  
0-586(18cm/7")  
2:3

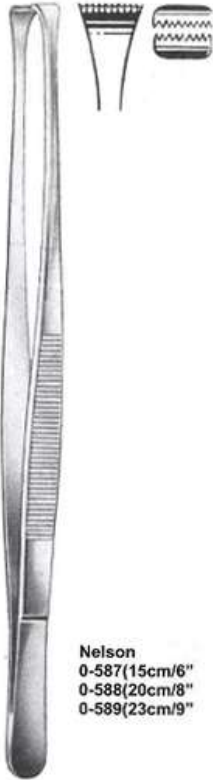

**Nelson**  
0-587(15cm/6")  
0-588(20cm/8")  
0-589(23cm/9")

**TISSUE FORCEPS**



**Lane**  
0-590(14.5cm/5 1/4")  
0-591(20cm/8")



**Lane**  
0-592(14.5cm/5 1/4")  
0-593(20cm/8")



**Brown**  
0-594(15cm/6")  
0-595(20cm/8")



**Treves**  
0-596(13cm/5")  
0-597(15cm/6")

**CILIA FORCEPS**



**Bergh**  
0-598(10.5cm)4 1/4"



**Barraquer**  
0-599(10.5cm)4 1/4"



**Gradle**  
0-600(10cm)4"



**Henny**  
0-601(10cm)4"

**CILIA FORCEPS**



**0-602**  
9cm)3 1/2"



**0-603**  
9cm)3 1/2"



**Douglas**  
0-604  
9cm)3 1/2"



**Douglas**  
0-605  
9cm)3 1/2"



**Beer**  
0-606(6.5cm)2 1/2"  
0-607(8cm)3 1/4"  
0-608(9cm)3 1/2"

### SPLINTER FORCEPS

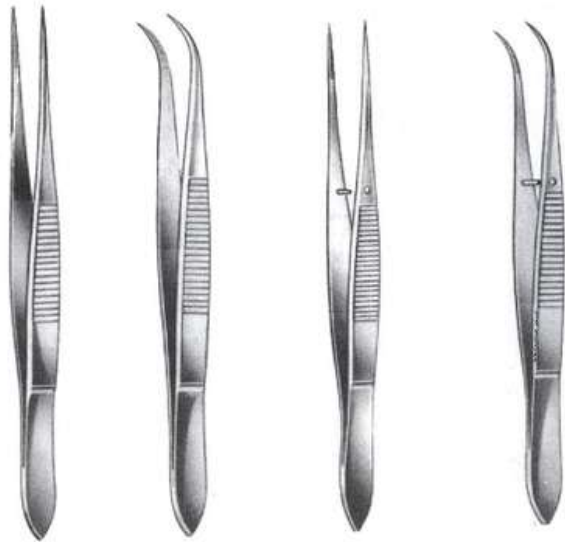

- |                  |                  |                  |                  |
|------------------|------------------|------------------|------------------|
| 0-609(8cm)3¼"    | 0-615(8cm)3¼"    | 0-621(8cm)3¼"    | 0-627(8cm)3¼"    |
| 0-610(9cm)3½"    | 0-616(9cm)3½"    | 0-622(9cm)3½"    | 0-628(9cm)3½"    |
| 0-611(10.5cm)4¼" | 0-617(10.5cm)4¼" | 0-623(10.5cm)4¼" | 0-629(10.5cm)4¼" |
| 0-612(11.5cm)4½" | 0-618(11.5cm)4½" | 0-624(11.5cm)4½" | 0-630(11.5cm)4½" |
| 0-613(13cm)5"    | 0-619(13cm)5"    | 0-625(13cm)5"    | 0-631(13cm)5"    |
| 0-614(14.5cm)5½" | 0-620(14.5cm)5½" | 0-626(14.5cm)5½" | 0-632(14.5cm)5½" |

### SPLINTER FORCEPS



- |                     |               |                      |                      |
|---------------------|---------------|----------------------|----------------------|
| <b>Feilchenfeld</b> | <b>Hunter</b> | <b>Water-Carmalt</b> | <b>Water-Carmalt</b> |
| 0-633(8cm)3¼"       | 0-636         | 0-638                | 0-639                |
| 0-634(9cm)3½"       | (10.5cm)4¼"   | (10.5cm)4¼"          | (10.5cm)4¼"          |
| 0-635(11.5cm)4½"    |               |                      |                      |
|                     | <b>Hunter</b> |                      |                      |
|                     | 0-637         |                      |                      |
|                     | (10.5cm)4¼"   |                      |                      |

### TISSUE FORCEPS

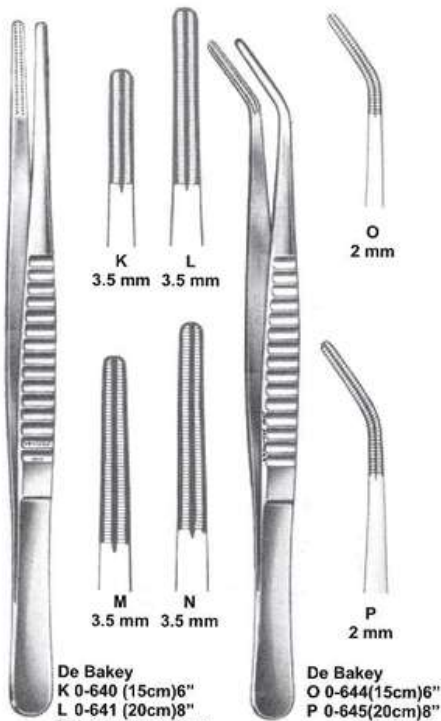

- |                   |                 |
|-------------------|-----------------|
| <b>De Bakay</b>   | <b>De Bakay</b> |
| K 0-640 (15cm)6"  | O 0-644(15cm)6" |
| L 0-641 (20cm)8"  | P 0-645(20cm)8" |
| M 0-642 (24cm)9½" |                 |
| N 0-643 (30cm)12" |                 |

### TISSUE FORCEPS

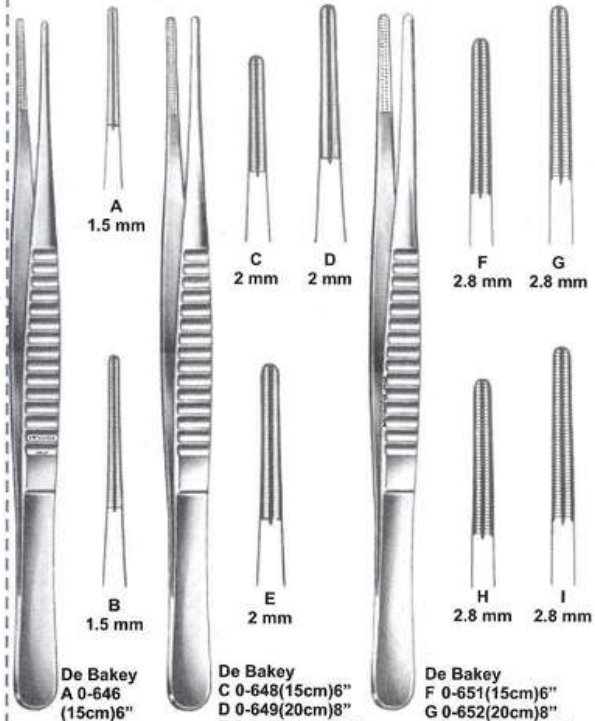

- |                 |                  |                  |
|-----------------|------------------|------------------|
| <b>De Bakay</b> | <b>De Bakay</b>  | <b>De Bakay</b>  |
| A 0-646         | C 0-648(15cm)6"  | F 0-651(15cm)6"  |
| (15cm)6"        | D 0-649(20cm)8"  | G 0-652(20cm)8"  |
| B 0-647         | E 0-650(24cm)9½" | H 0-653(24cm)9½" |
| (20cm)8"        |                  | I 0-654(30cm)12" |

**Iris FORCEPS**



**Iris FORCEPS**

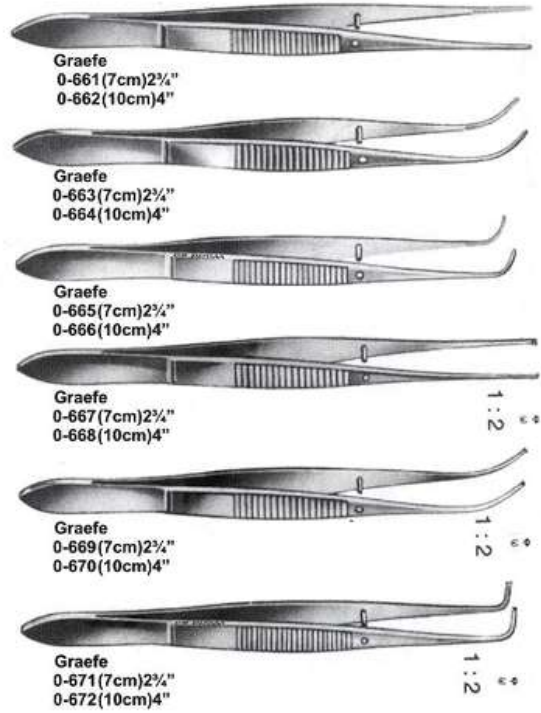

**Iris FORCEPS**

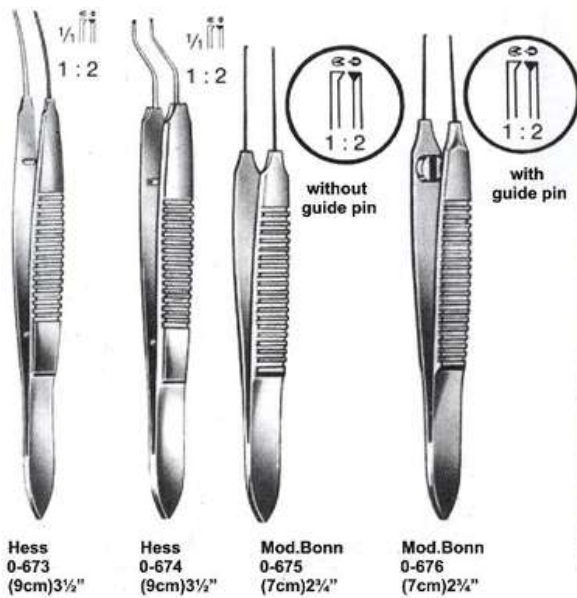

**Iris FORCEPS**

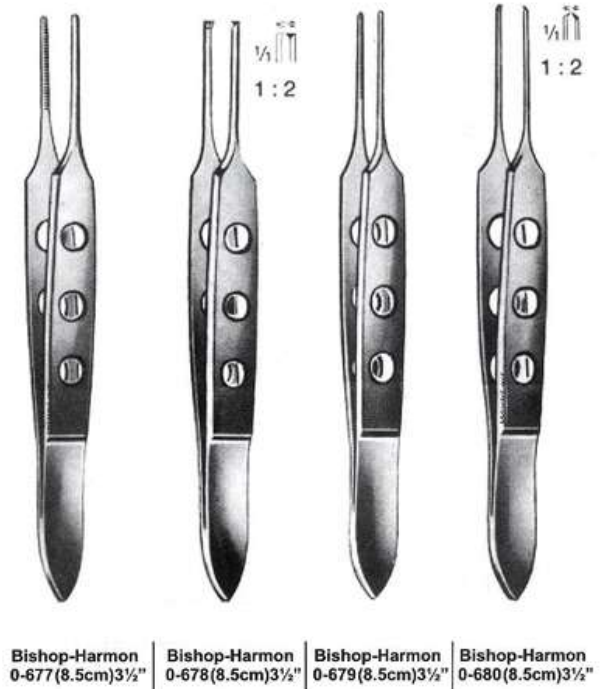



## SUTURE FORCEPS

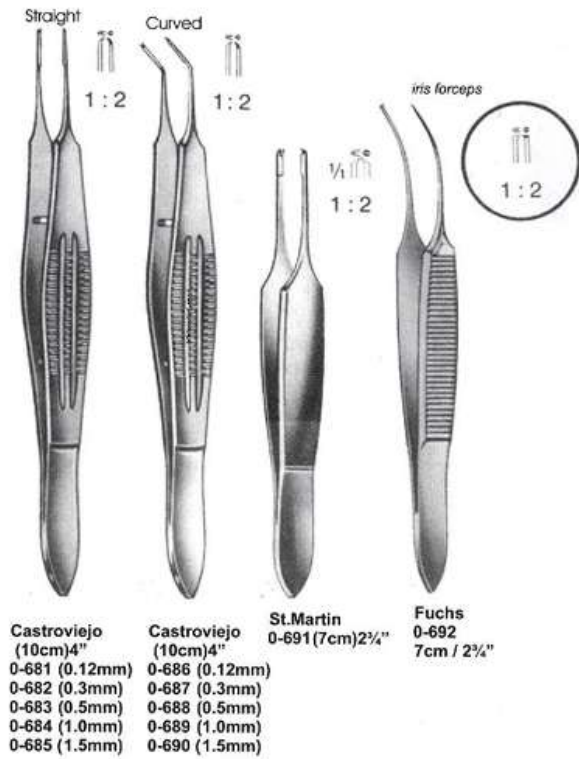

## CAPSULAR FORCEPS

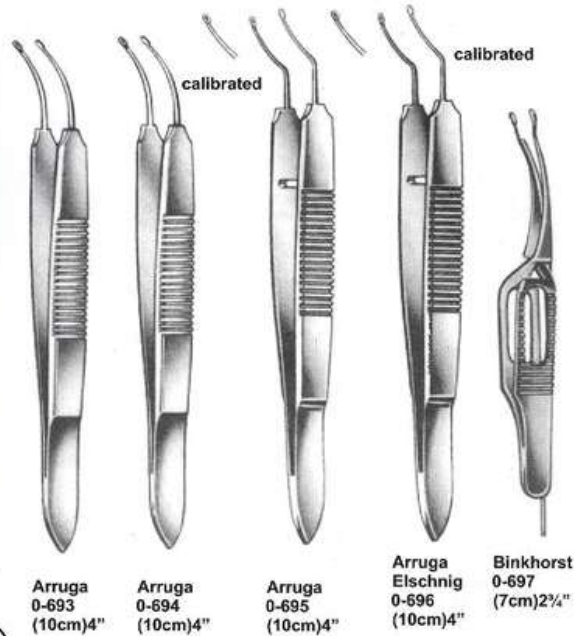

21

## FIXATION & GRASPING FORCEPS

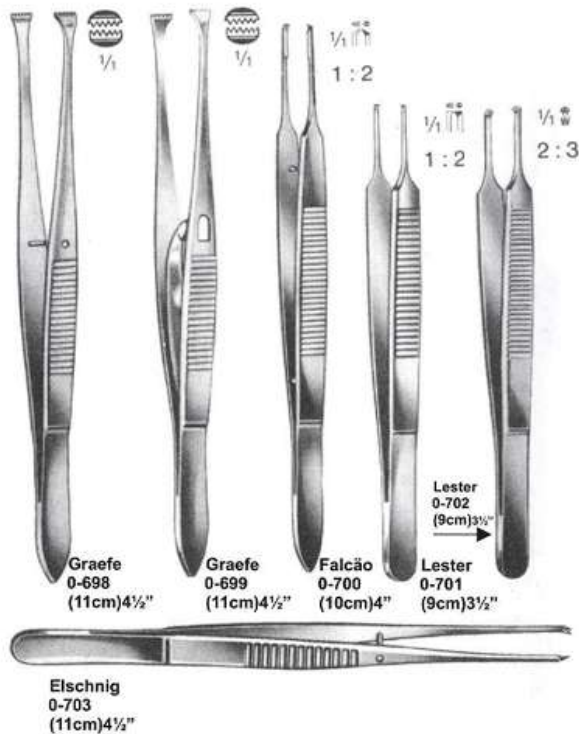

## VARIOUS EYE FORCEPS

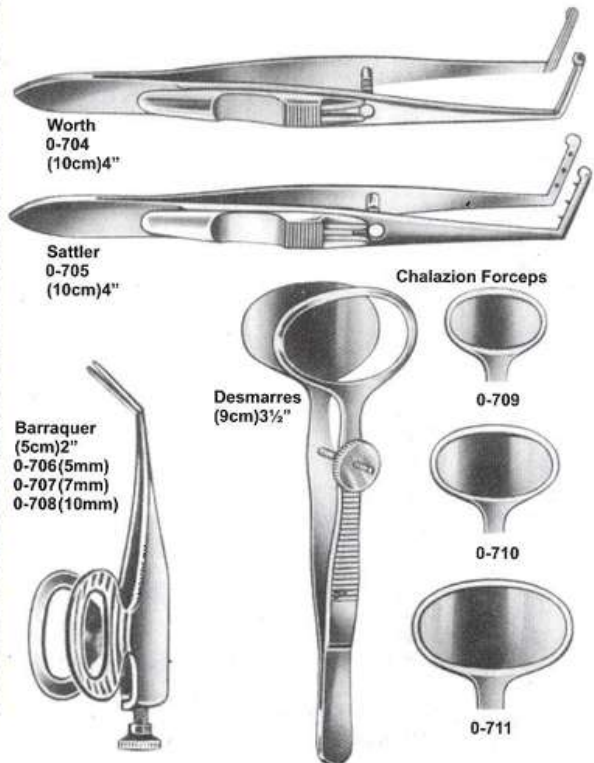

## MICROSCOPIC & EYE SCISSORS

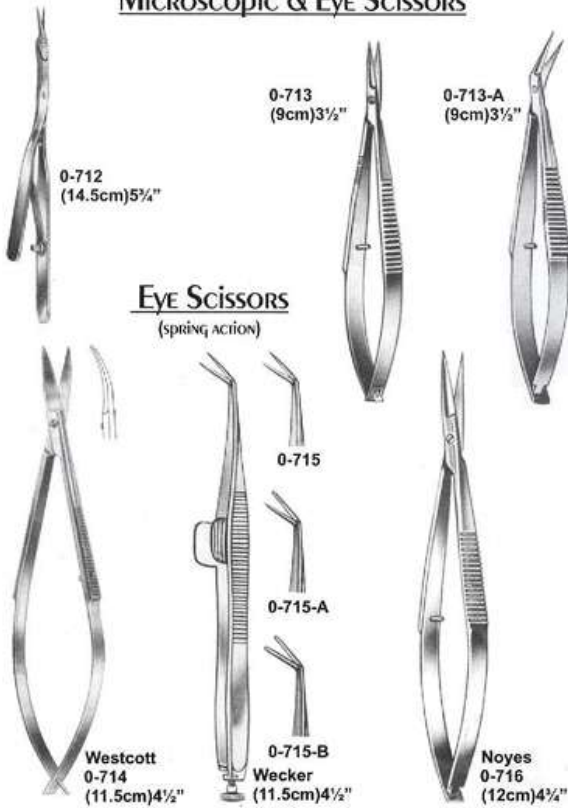

### Eye Scissors (spring action)

## Eye Scissors (spring action)

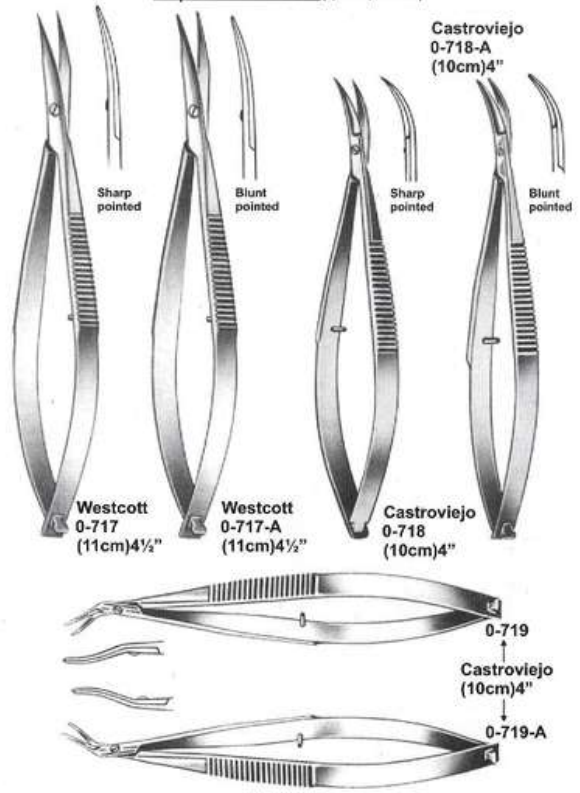

22

## MICRO SCISSORS (spring action)

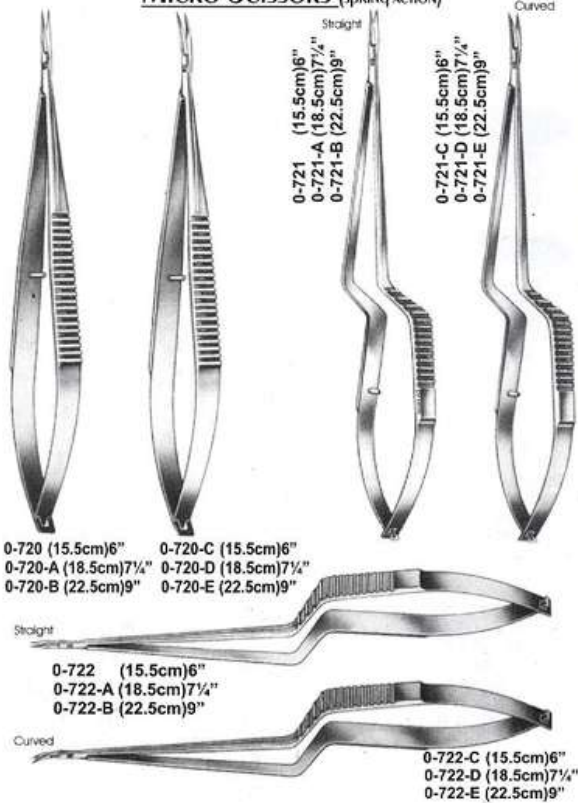

## MICRO SCISSORS (spring action)

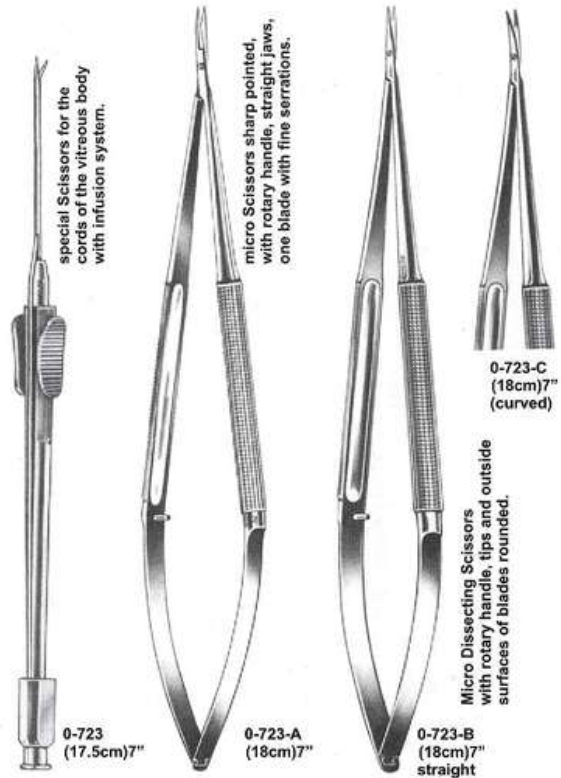

SUTURE INSTRUMENTS



Ochsner  
0-723D  
(14cm)5¼"



Lange  
0-723E  
(10cm)4"



Wachenfeldt  
0-723F  
(12cm)4½"

SUTURE INSTRUMENTS



Childe  
0-723G  
(18cm)7"



Michel  
0-723H  
(12cm)4¾"



Wachenfeldt  
0-723J  
(12.5cm)5"

SUTURE INSTRUMENTS



Hegenbarth  
0-723K  
(12.5cm)5"



Wachenfeldt  
0-723L  
(12.5cm)5"



Michel  
0-723M  
(12cm)4¾"



Mod-Michel  
0-723N  
(12cm)4¾"

SUTURE INSTRUMENTS

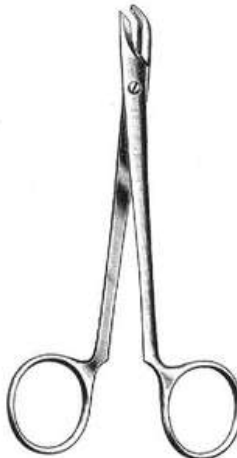

Collin  
0-723P  
(13cm)5"



Richter-Heath  
0-723R  
(14cm)5½"



**ARTERY FORCEPS**

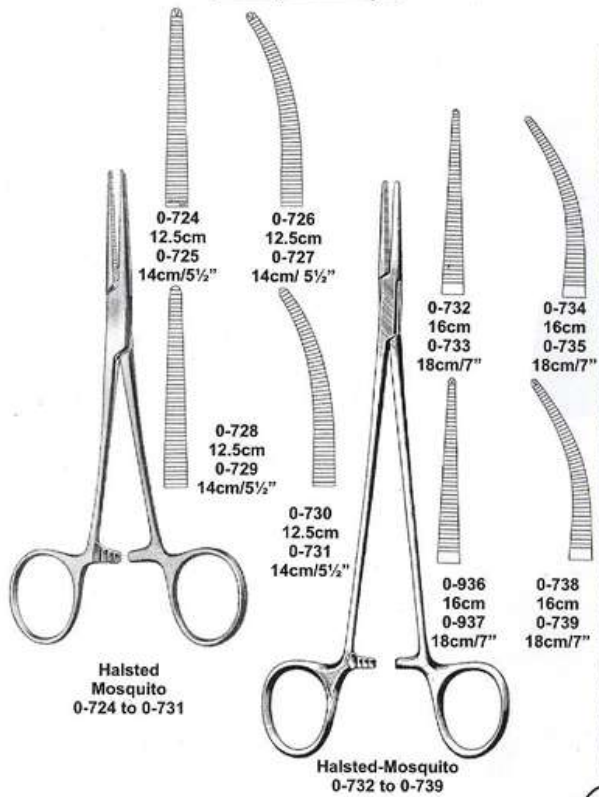

**ARTERY FORCEPS**

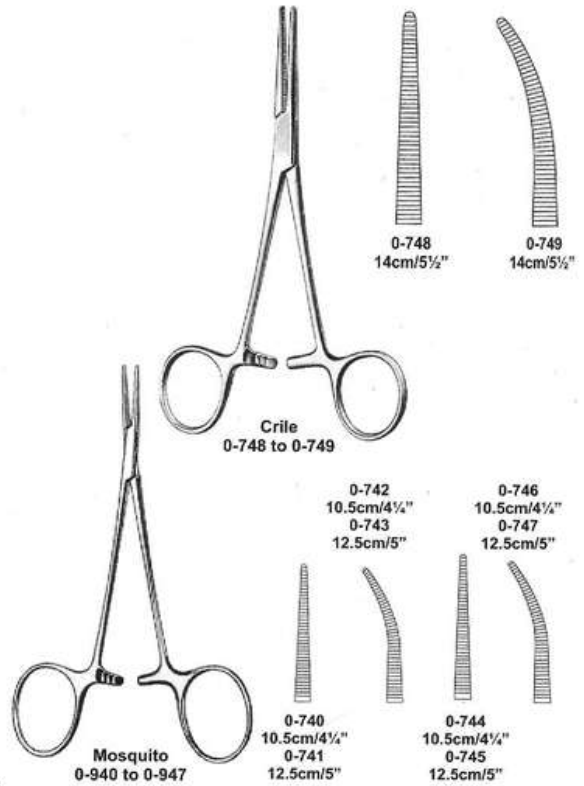

24

**ARTERY FORCEPS**

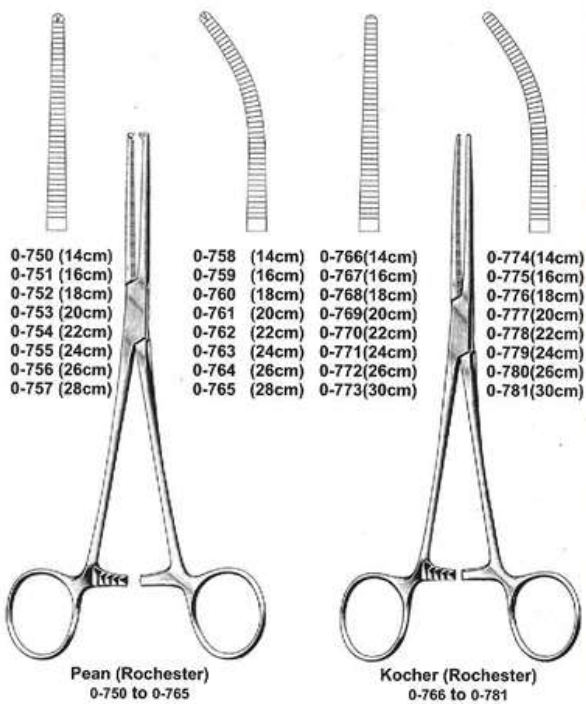

**ARTERY FORCEPS**

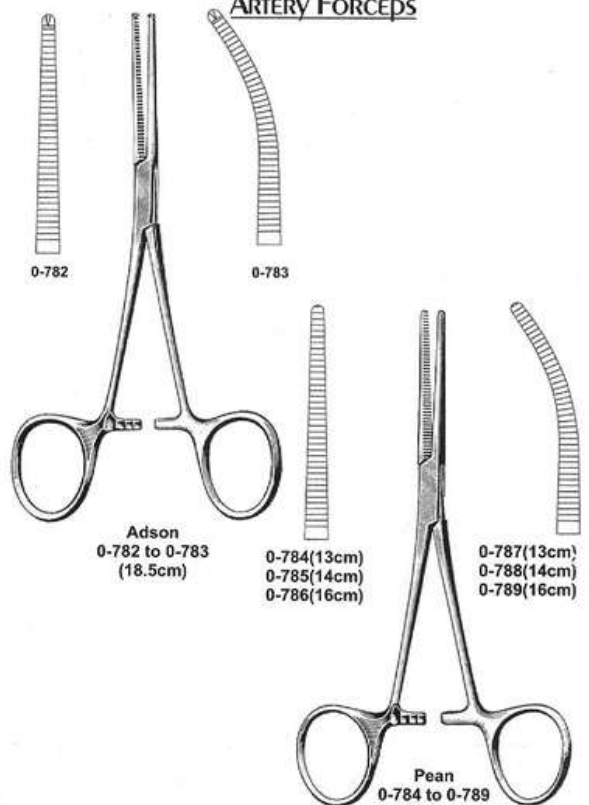

ARTERY FORCEPS

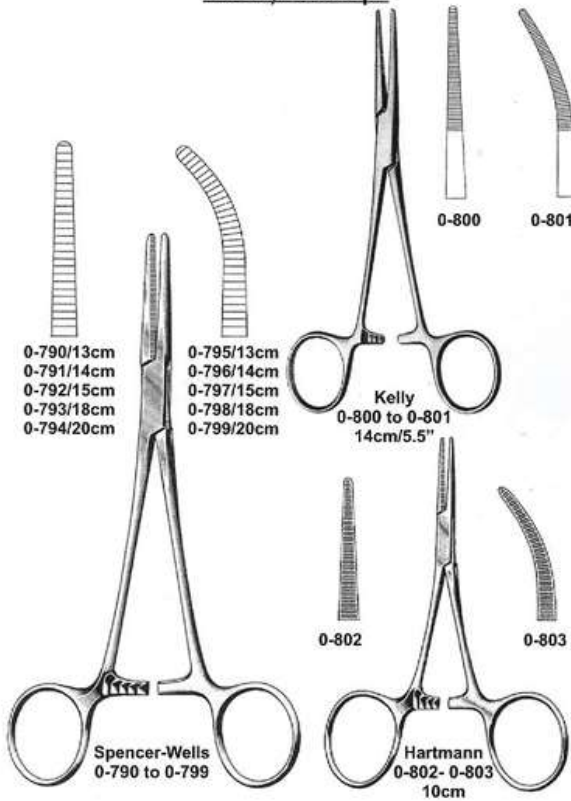

ARTERY FORCEPS

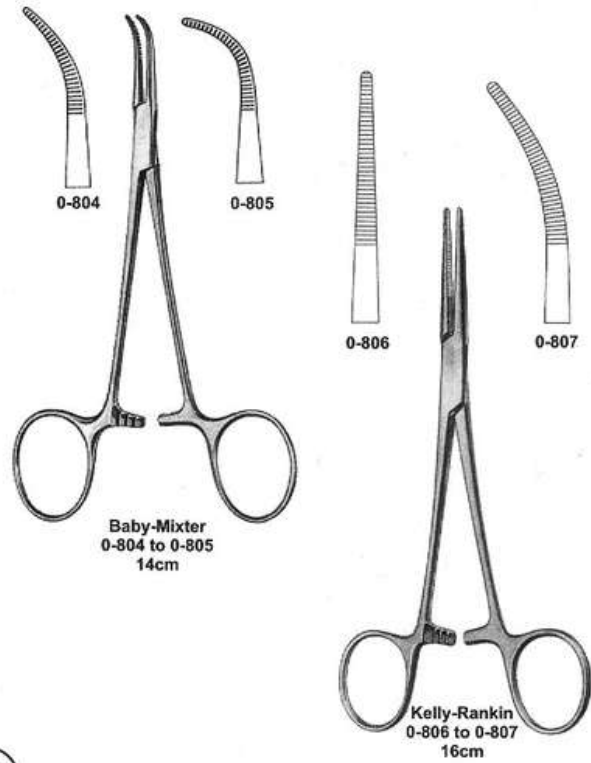

ARTERY & HYSTERECTOMY FORCEPS

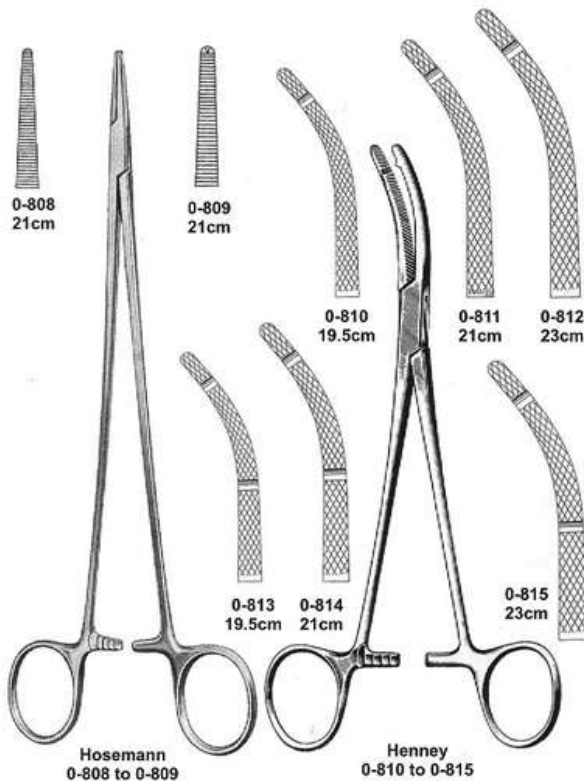

ARTERY & HYSTERECTOMY FORCEPS



**NEEDLE HOLDERS**

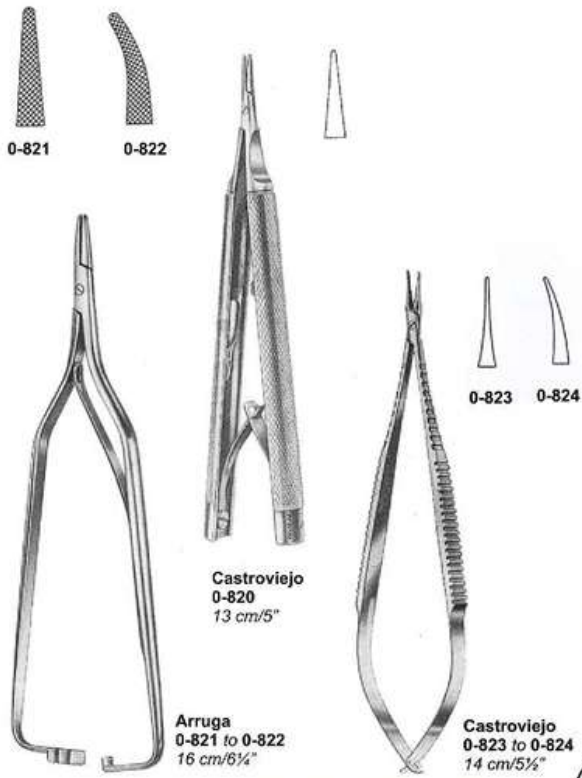

**NEEDLE HOLDERS**

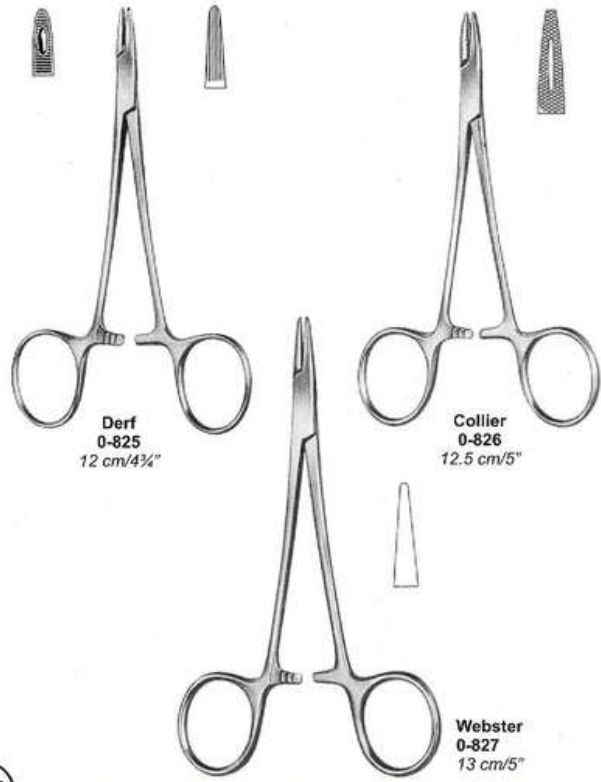

**NEEDLE HOLDERS**

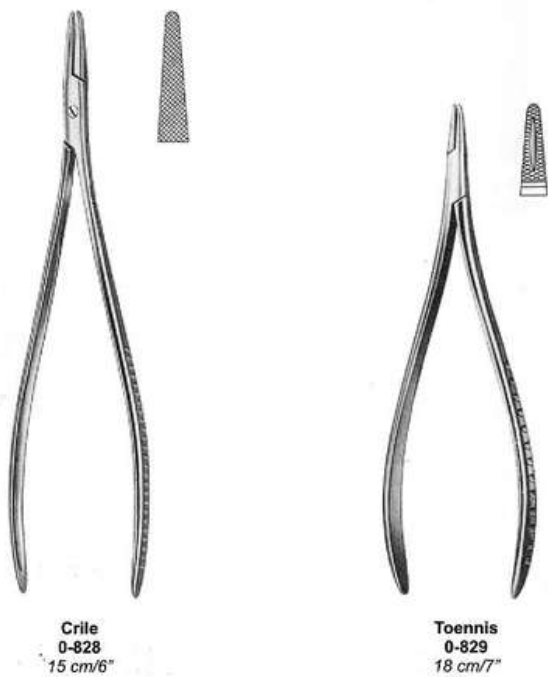

**NEEDLE HOLDERS**

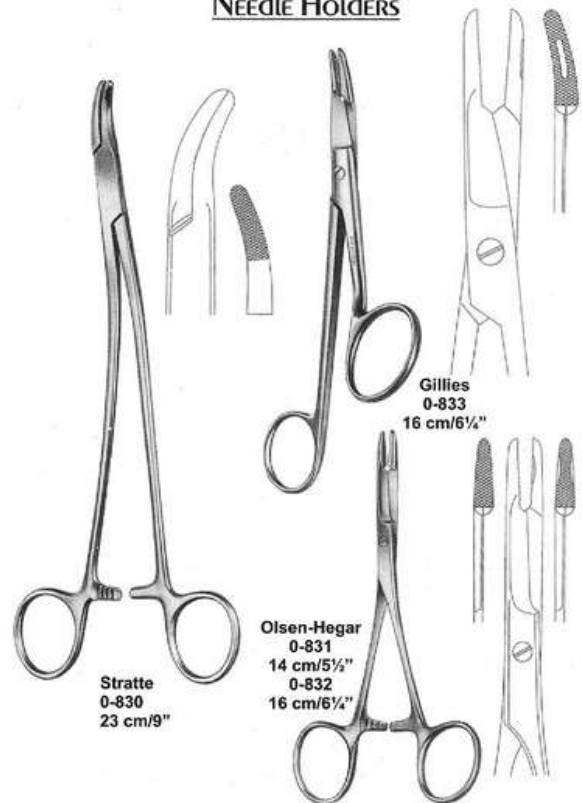



## Sponge Holding Forceps

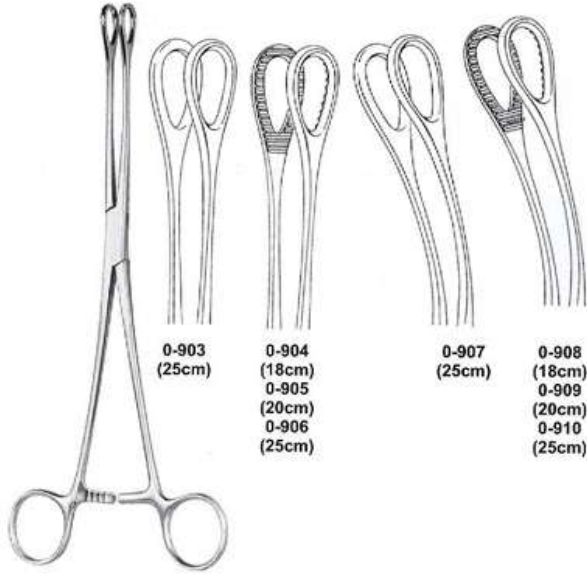

Foerster  
0-903 to 0-909

## Sponge & Dressing Forceps

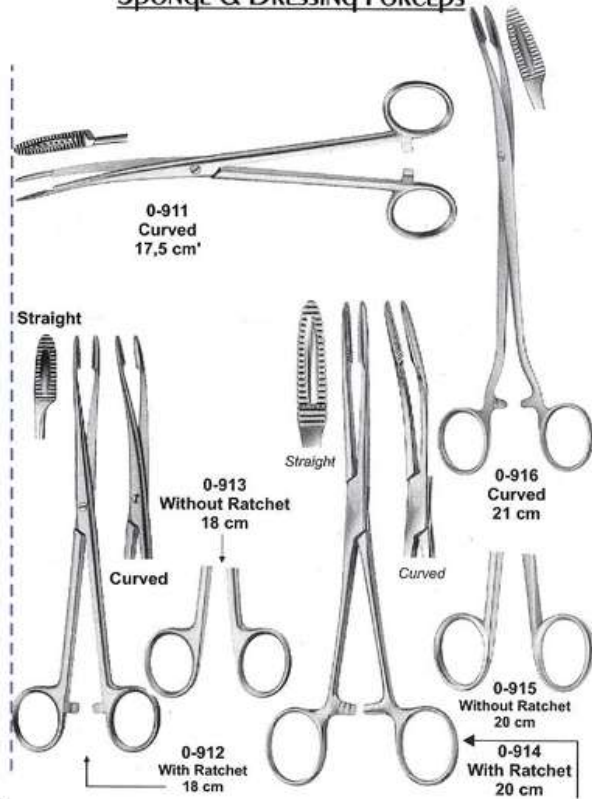

30

## Tissu & Organ Holding Forceps

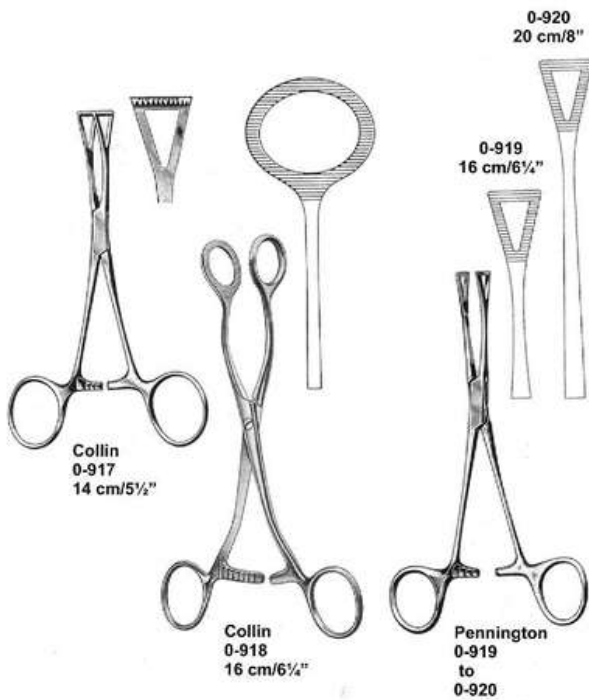

Collin  
0-917  
14 cm/5 1/2"

Collin  
0-918  
16 cm/6 1/4"

Pennington  
0-919  
to  
0-920

## Tongue Holding Forceps

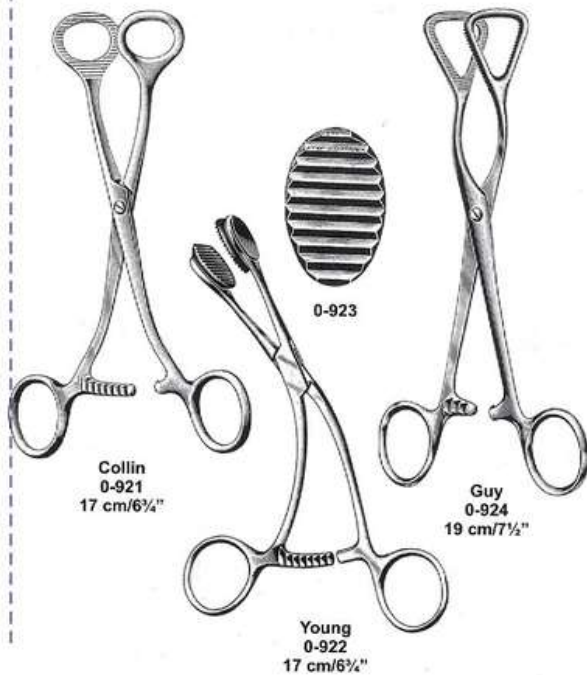

Collin  
0-921  
17 cm/6 3/4"

Young  
0-922  
17 cm/6 1/2"

Guy  
0-924  
19 cm/7 1/2"

**TONGUE DEPRESSORS,**

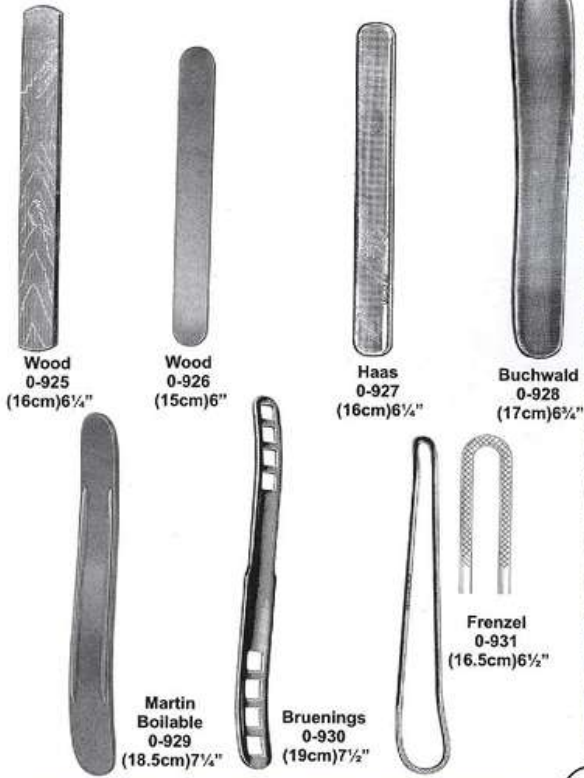

**MOUTH GAGS**

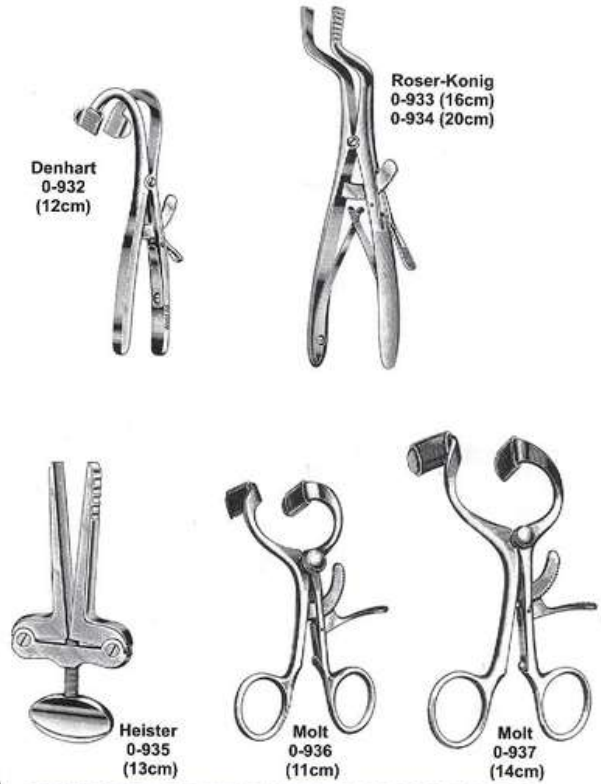

31

**CHEEK & Lip RETRACTORS**

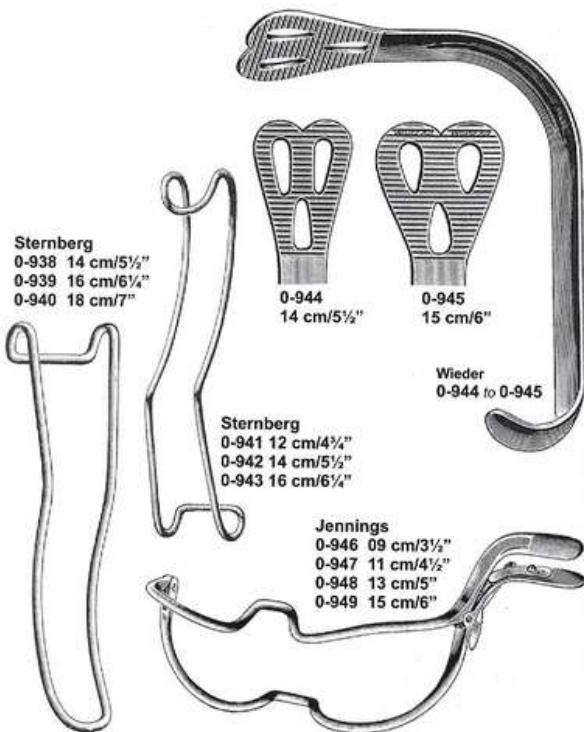

**TONGUE DEPRESSORS,**



## VAGINAL SPECULA



## VAGINAL SPECULA



36

## VAGINAL SPECULA

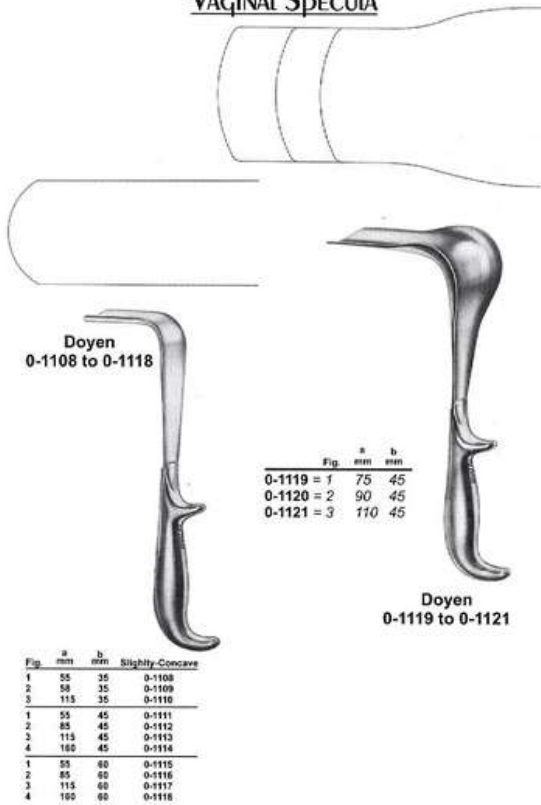

## VAGINAL SPECULA & RETRACTORS





## VAGINAL SPECULA & RETRACTORS

**Sims**  
0-1127  
65 x 25 mm  
70 x 30 mm  
0-1128  
70 x 30 mm  
70 x 35 mm  
0-1129  
85 x 35 mm  
90 x 40 mm

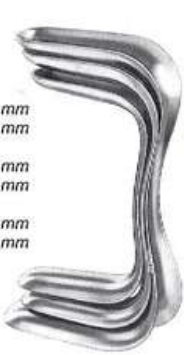

**Jackson**  
0-1130  
75 x 35 mm  
0-1131  
90 x 35 mm  
0-1132  
100 x 35 mm  
0-1133  
75 x 40 mm  
0-1134  
90 x 40 mm  
0-1135  
100 x 40 mm



## VAGINAL SPECULA & RETRACTORS

**Kristeller Specula**  
0-1144 Fig. 1  
70 x 27 mm  
0-1145 Fig. 2  
80 x 30 mm  
0-1146 Fig. 3  
90 x 36 mm



**Kristeller Retractors**  
0-1147 Fig. 1  
75 x 23 mm  
0-1148 Fig. 2  
85 x 26 mm  
0-1149 Fig. 3  
100 x 32 mm



**Kristeller**  
Set of 1 Speculum & 1 Retractor each  
0-1150 Fig. 1  
0-1151 Fig. 2  
0-1152 Fig. 3



With Conically Shaped blades, Virgin Sizes



**Kallmorgen Vaginal Specula**  
0-1136  
70 x 40 mm  
0-1137  
90 x 40 mm

**Vaginal Retractors**  
0-1138  
70 x 33 mm  
0-1139  
90 x 33 mm

**Mathieu Vaginal Specula**  
0-1140  
95 x 16 mm  
0-1141  
95 x 16 mm  
0-1142  
95 x 30 mm

**Vaginal Retractors**  
0-1143  
100 x 14 mm  
0-1144  
100 x 26 mm



**Kristeller Specula**  
0-1153  
105 x 18 mm  
0-1154  
105 x 21 mm

**Kristeller Retractors**  
0-1155  
110 x 14 mm  
0-1156  
110 x 17 mm

**Kristeller**  
Set of 1 Speculum & 1 Retractor each  
0-1157  
0-1158

37

## VAGINAL SPECULA

Specula flat hollow

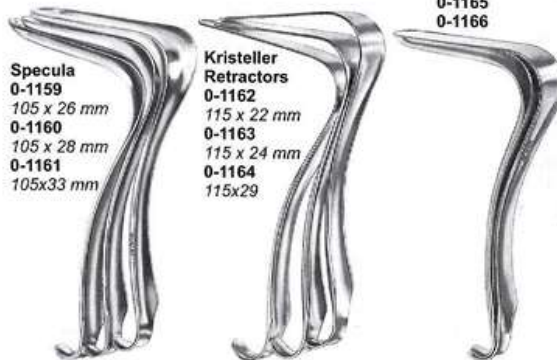

**Specula**  
0-1159  
105 x 26 mm  
0-1160  
105 x 28 mm  
0-1161  
105x33 mm

**Kristeller Retractors**  
0-1162  
115 x 22 mm  
0-1163  
115 x 24 mm  
0-1164  
115x29

**Kristeller**  
Set of 1 Speculum & 1 Retractor each  
0-1165  
0-1166

## VAGINAL SPECULA

Specula Deep Hollow



**Kristeller Specula**  
0-1167  
110 x 27 mm  
0-1168  
110 x 30 mm  
0-1169  
110 x 36 mm

**Kristeller Retractors**  
0-1170  
115 x 23 mm  
0-1171  
115 x 26 mm  
0-1172  
115 x 32 mm

**Kristeller**  
Set of 1 Speculum & 1 Retractor each  
0-1173  
0-1174  
0-1175

## RETRACTORS



## PROSTATIC RETRACTORS



38

## VAGINAL SPECULUM, RETRACTORS

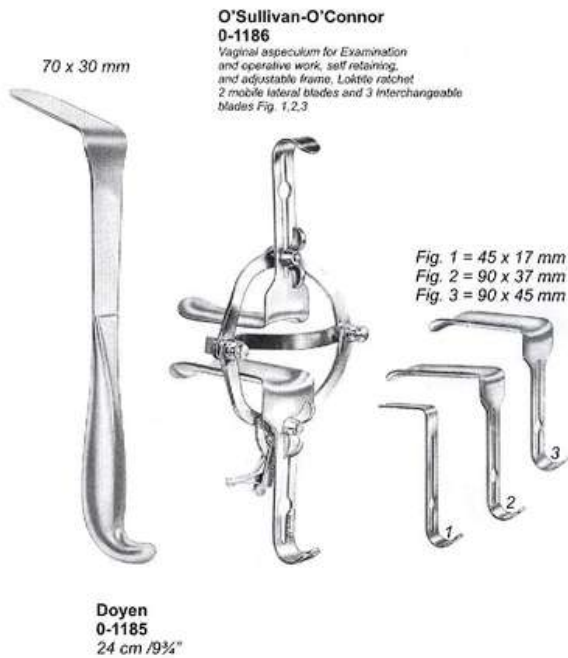

## VAGINAL SPECULUM, RETRACTORS



**ANAL RETRACTORS, RECTAL SPECULA  
SPHINCTEROSCOPES, ANOSCOPE, PROCTOSCOPES**



**Newman**  
0-1201 16 mm Ø x 63 mm  
0-1202 19 mm Ø x 63 mm  
0-1203 23 mm Ø x 63 mm



**Kelly**  
0-1204 21 mm Ø x 50 mm  
0-1205 27 mm Ø x 50 mm



**Kelly**  
0-1206 22 mm Ø x 50 mm  
0-1207 22 mm Ø x 100 mm  
0-1208 22 mm Ø x 140 mm

**RECTAL SPECULA, ANAL  
RETRACTORS, ANOSCOPE**

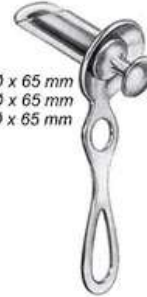

**Hirschmann**  
0-1209 16 mm Ø x 65 mm  
0-1210 19 mm Ø x 65 mm  
0-1211 22 mm Ø x 65 mm



**Ives-Fansler**  
0-1212  
22 mm Ø



**Ives-Fansler**  
0-1213  
22 mm Ø

39

**RETRACTORS**

**RETRACTORS**



**Richardson**  
0-1214 to 0-1216  
24 cm

**Richardson**  
0-1217  
24 cm

**Kelly**  
0-1218  
26 cm

**Richardson-Eastmann**  
0-1219 Fig. 1 26 cm  
0-1220 Fig. 2 28 cm

**Deaver**

0-1224-A 23 cm  
0-1224-B 21.5 cm  
0-1224-C 18 cm



**Deaver**  
0-1221  
30 cm

**Deaver**  
0-1222  
30 cm

**Deaver**  
0-1223  
30 cm

**Deaver**  
0-1224-  
30 cm

**Deaver**  
0-1225  
36 cm



**RETRACTORS**

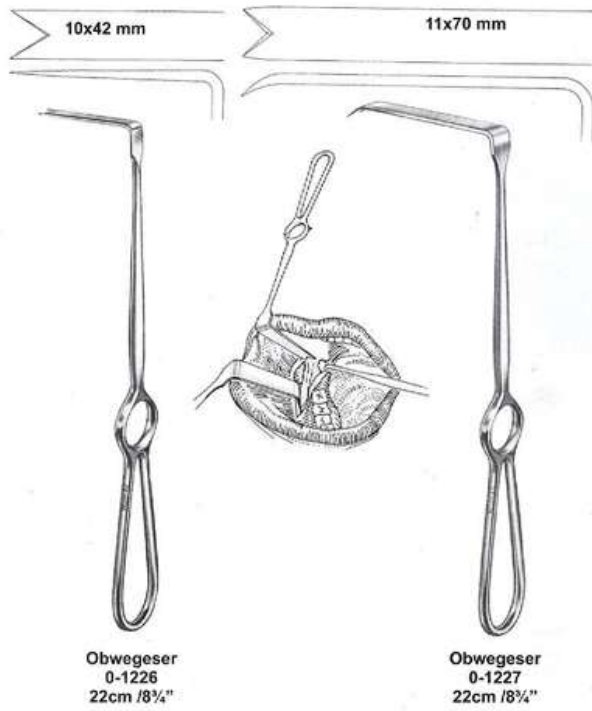

**RETRACTORS**

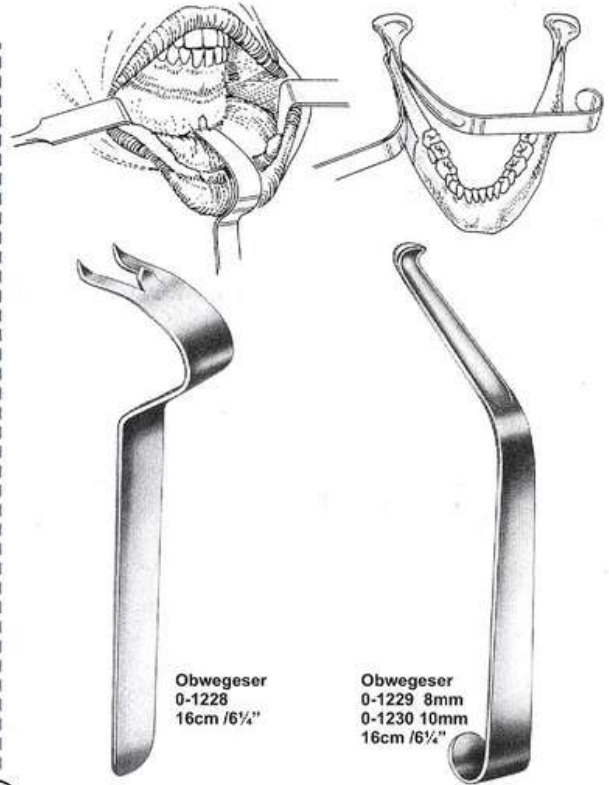

40

**RHINOPLASTIC INSTRUMENTS**

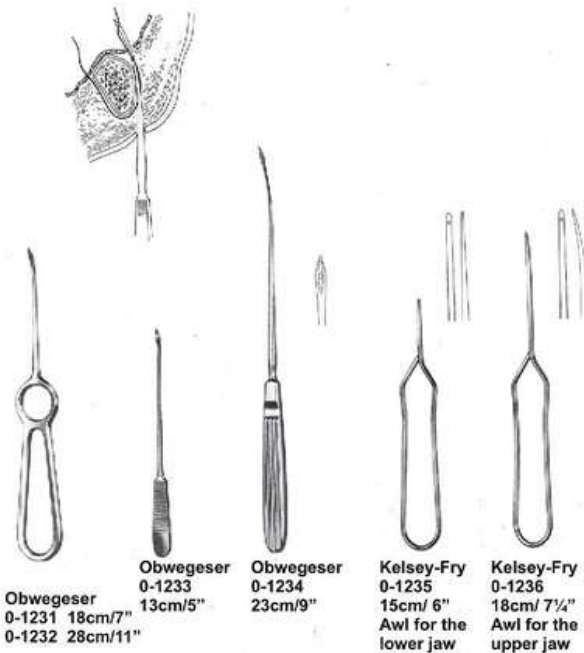

**RHINOPLASTIC INSTRUMENTS**



**RECTAL SPECULA, ANAL RETRACTORS**



**RECTAL SPECULA**



**RECTAL SPECULA**

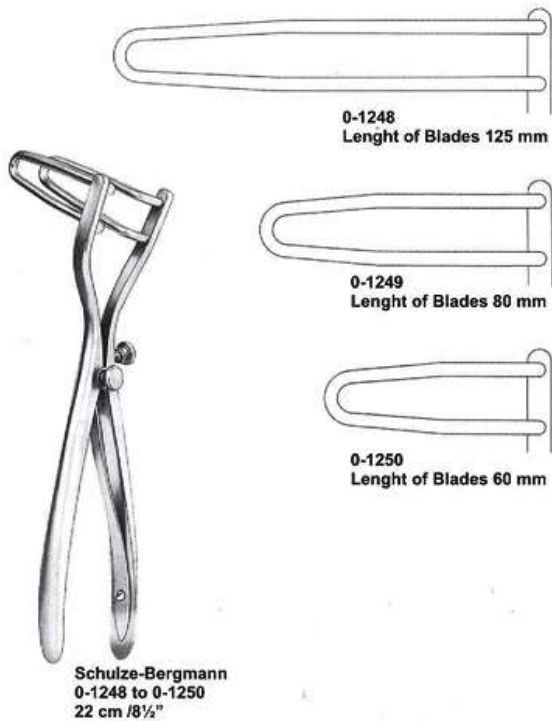

**RECTAL SPECULA, ANAL RETRACTORS**

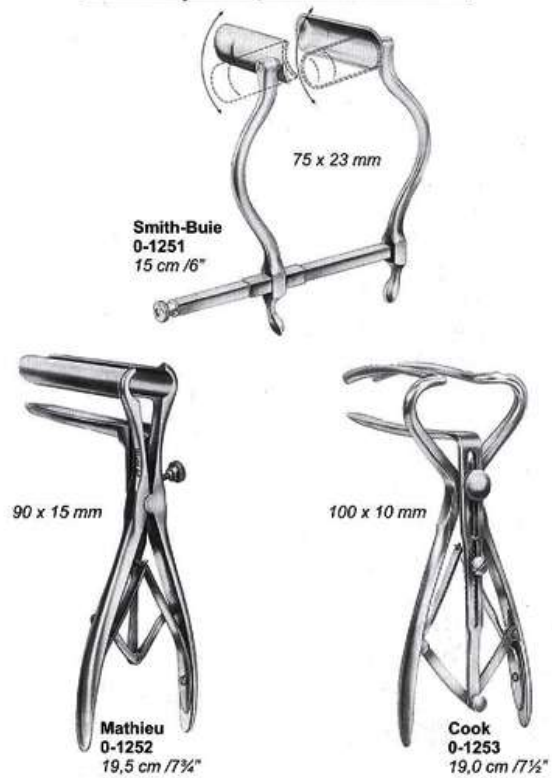

ABDOMINAL RETRACTORS

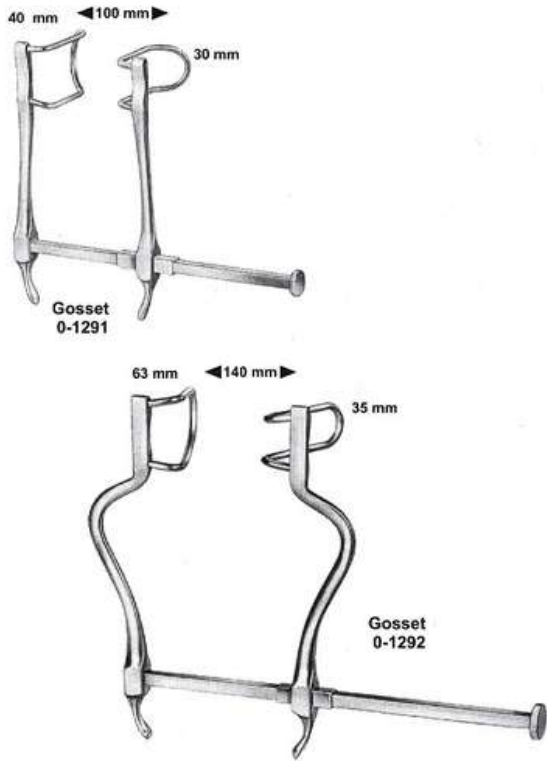

ABDOMINAL RETRACTORS



ABDOMINAL RETRACTORS

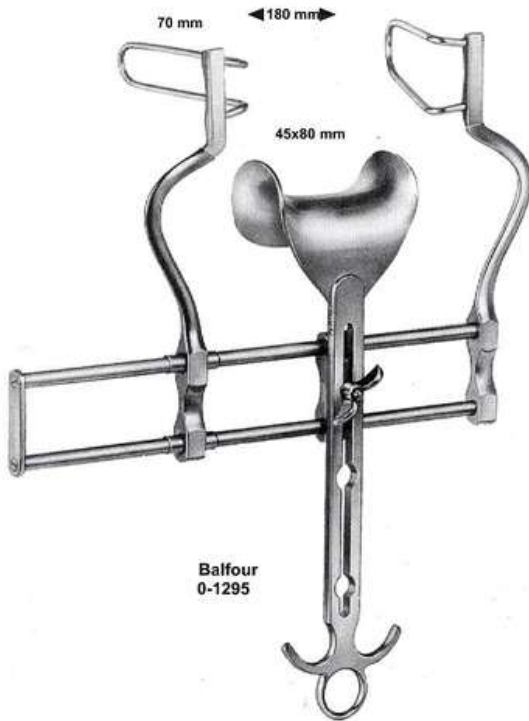

ABDOMINAL RETRACTORS





**RETRACTORS**



0-1297  
45x45 mm



Middeldorp  
25.5cm / 10"



0-1298  
45x50 mm



0-1299  
55x70 mm

**RETRACTORS**

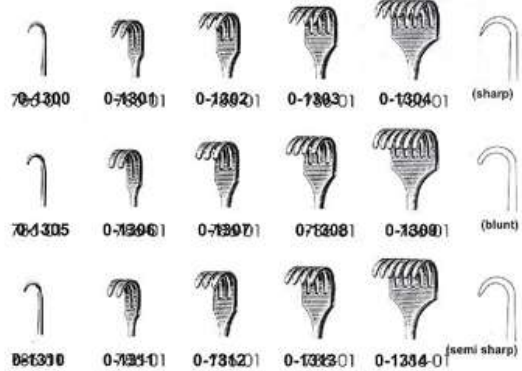

0-1300 (sharp)  
0-1301 (sharp)  
0-1302 (sharp)  
0-1303 (sharp)  
0-1304 (sharp)  
0-1305 (blunt)  
0-1306 (blunt)  
0-1307 (blunt)  
0-1308 (blunt)  
0-1309 (blunt)  
0-1310 (semi sharp)  
0-1311 (semi sharp)  
0-1312 (semi sharp)  
0-1313 (semi sharp)  
0-1314 (semi sharp)



Volkmann  
0-1300 to 0-1318  
21.5cm/8½"



Volkmann  
0-1315  
21.5cm/8½"



Volkmann  
0-1316  
21.5cm/8½"



Volkmann  
0-1317 (sharp)  
20cm/8"  
0-1318 (blunt)  
20cm/8"

**RETRACTORS**

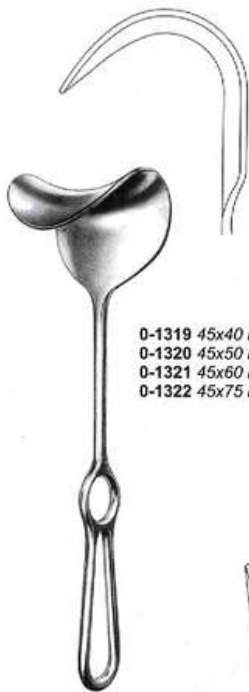

Fritsch  
24 cm/9½"

0-1319 45x40 mm  
0-1320 45x50 mm  
0-1321 45x60 mm  
0-1322 45x75 mm

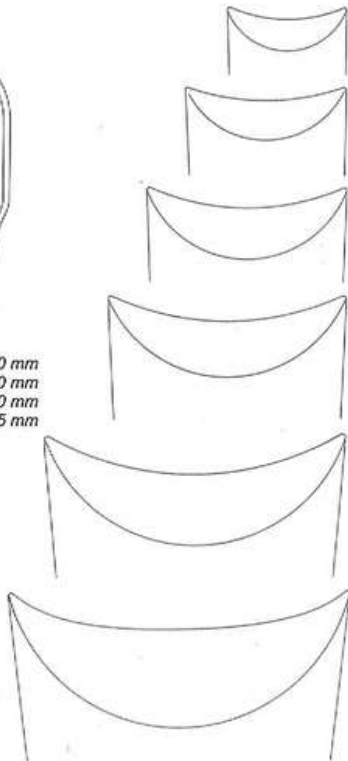

**RETRACTORS**



0-1323  
36x30 mm

Ollier  
22.5cm / 9"

0-1324  
36x60 mm

33x20 mm



Wassmund  
0-1325  
20cm / 8"

0-1326  
40x30 mm  
sharp

0-1327  
40x30mm  
blunt



Wassmund  
23.5cm / 9¼"

**RETRACTORS**



**Gelpi-Loktite**  
**0-1328**  
13 cm/5"

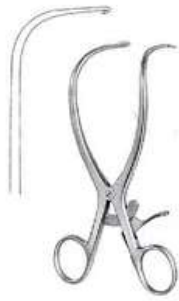

**Gelpi-Seiletz**  
**0-1329**  
15 cm/6"

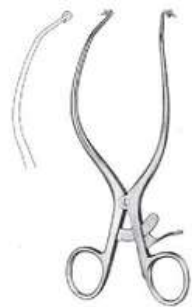

**Gelpi-Loktite**  
**0-1330**  
18 cm/7"

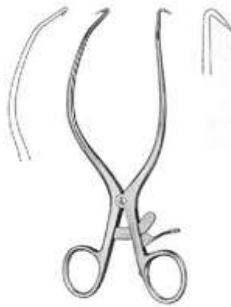

**Gelpi-Loktite**  
**0-1331**  
18 cm/7"

**RETRACTORS**



**Israel**  
**0-1332 to 0-1335**  
25 cm/10"



**0-1332**  
40 x 40 mm



**0-1333**  
40 x 50 mm



**0-1334**  
50 x 60 mm

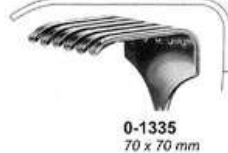

**0-1335**  
70 x 70 mm



**Langenbeck**  
**0-1336 to 0-1340**  
21 cm/8 1/2"



**0-1336**  
30 x 11 mm



**0-1337**  
30 x 14 mm



**0-1338**  
30 x 16 mm

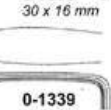

**0-1339**  
40 x 11 mm

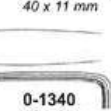

**0-1340**  
50 x 11 mm

**RETRACTORS**

**Weitlaner-Wullstein**  
**0-1341 sharp**  
**0-1342 blunt**  
13 cm/5"

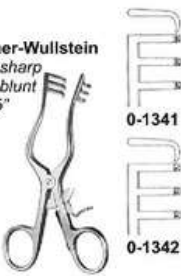

**Mollison**  
**0-1343**  
15 cm/6"



**Adson**  
**0-1344 to 0-1347**  
26.5 cm

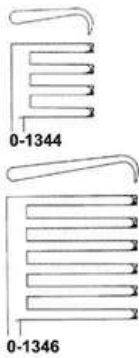

**0-1344**

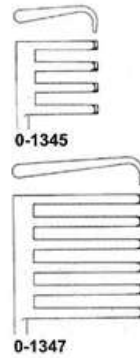

**0-1345**

**RETRACTORS**



**Mini-Langenbeck**  
**0-1348 to 0-1351**  
16 cm/6 1/2"



**Desmarres**  
**0-1352 to 0-1357**  
16 cm/6 1/2"

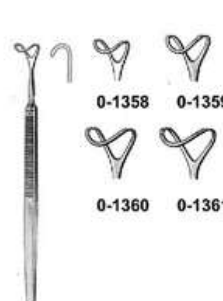

**0-1358 to 0-1361**  
16 cm/6 1/2"

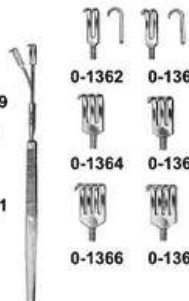

**0-1362 to 0-1367**  
16 cm/6 1/2"

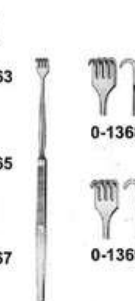

**0-1368 to 0-1369**  
16 cm/6 1/2"

**RETRACTORS**

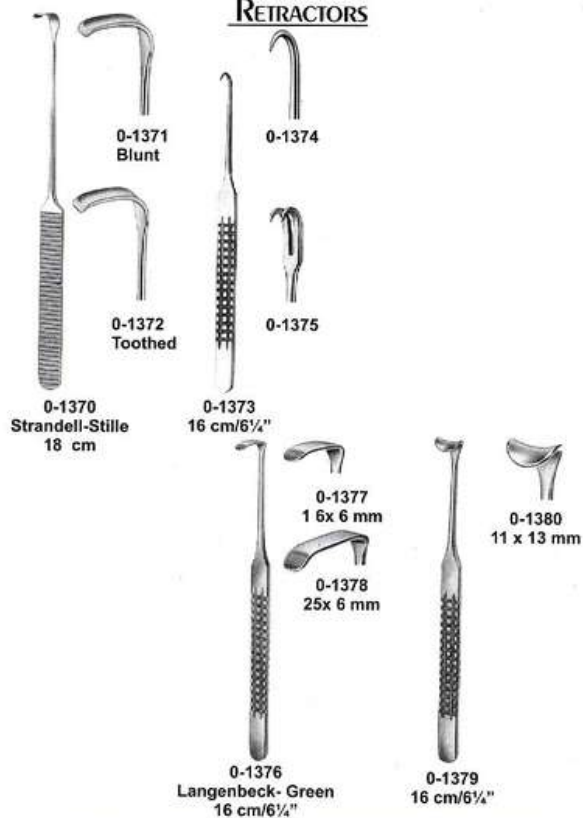

**NERVE ROOT RETRACTORS**

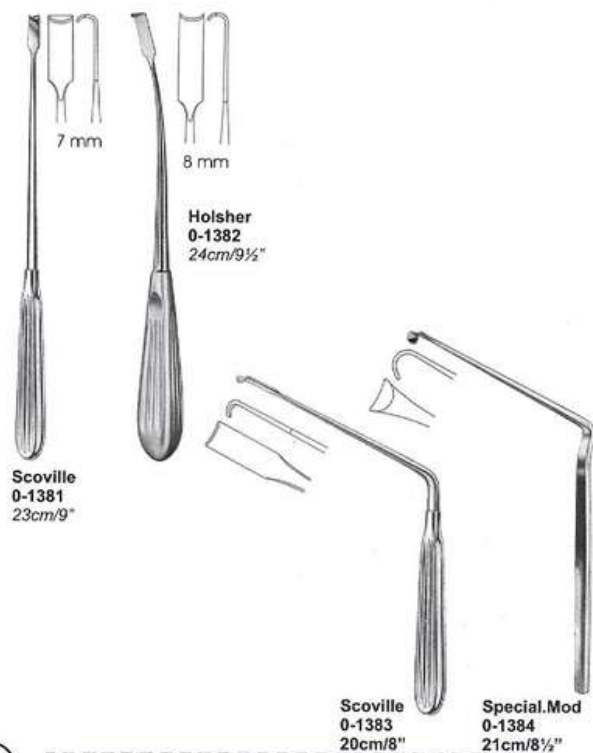

48

**RETRACTORS**

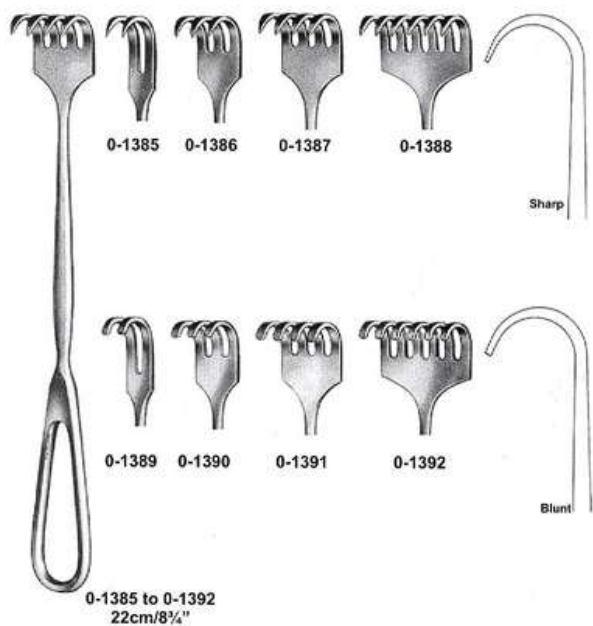

**RETRACTORS**

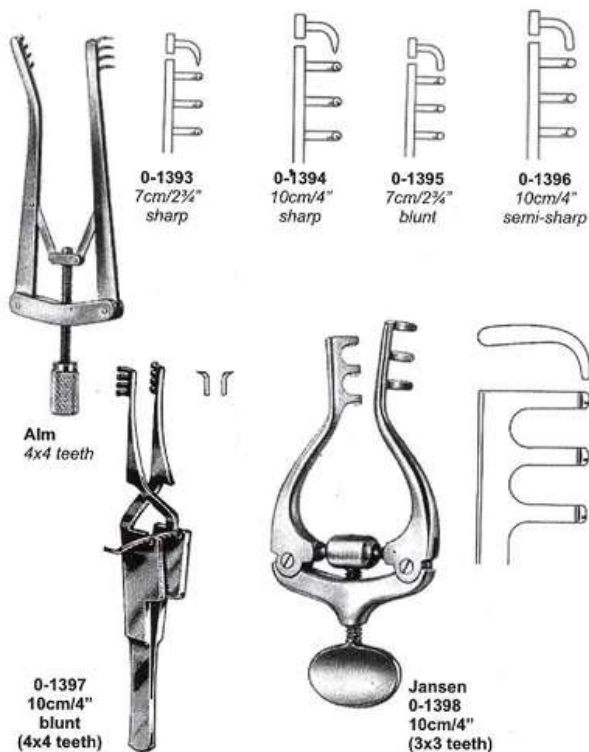



RETRACTORS

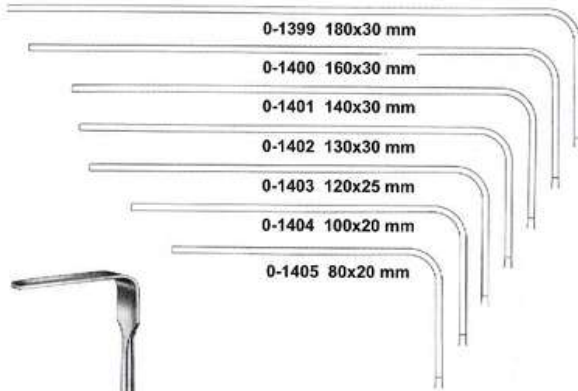

0-1399 180x30 mm

0-1400 160x30 mm

0-1401 140x30 mm

0-1402 130x30 mm

0-1403 120x25 mm

0-1404 100x20 mm

0-1405 80x20 mm



Brunner  
25cm/10"

RETRACTORS

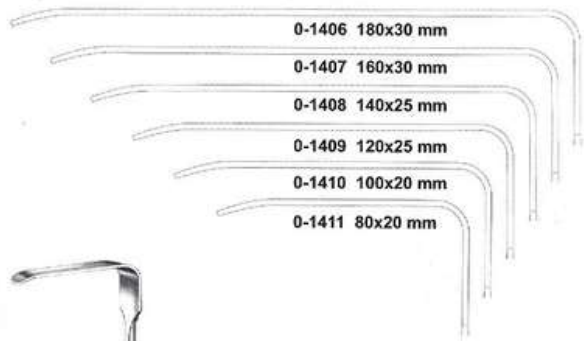

0-1406 180x30 mm

0-1407 160x30 mm

0-1408 140x25 mm

0-1409 120x25 mm

0-1410 100x20 mm

0-1411 80x20 mm



Brunner  
25cm/10"

RETRACTORS

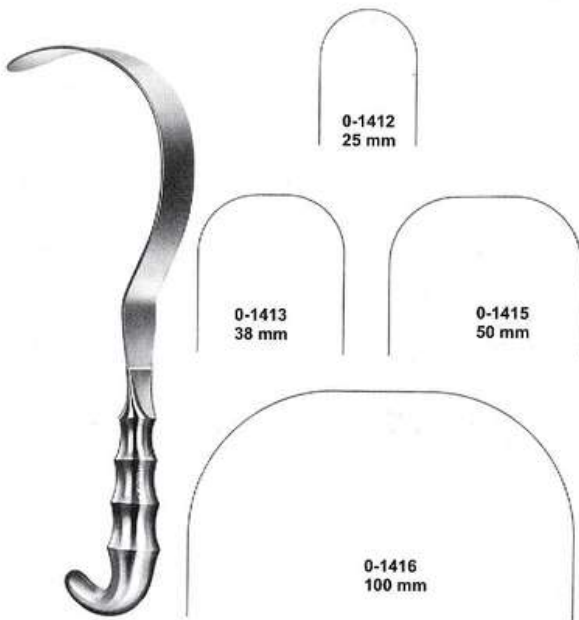

0-1412  
25 mm

0-1413  
38 mm

0-1415  
50 mm

0-1416  
100 mm

Deaver  
31cm/12¼"

RETRACTORS



0-1417  
127x40 mm  
0-1418  
127x62 mm

Harrington  
32cm/12½"

**RETRACTORS**



**RETRACTORS**

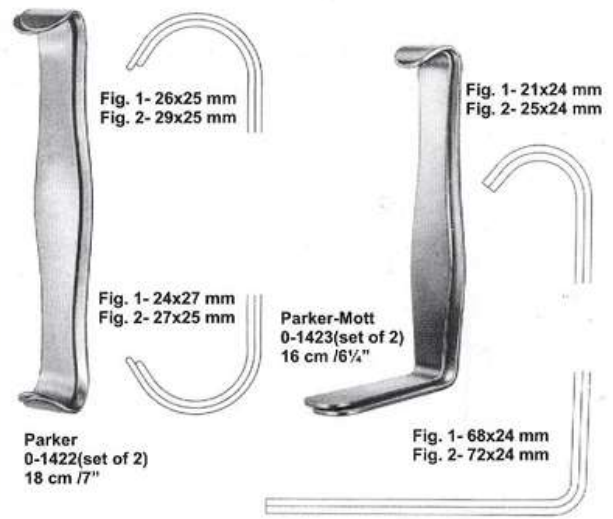

**RETRACTORS**

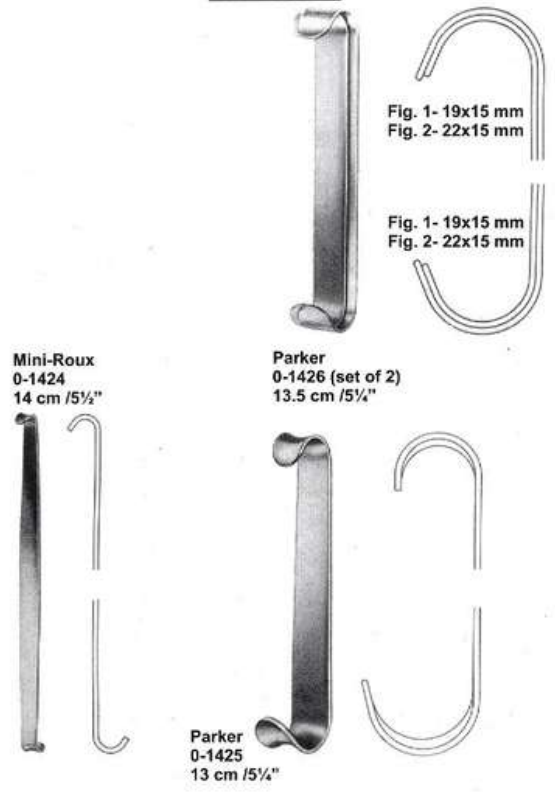

**RETRACTORS**

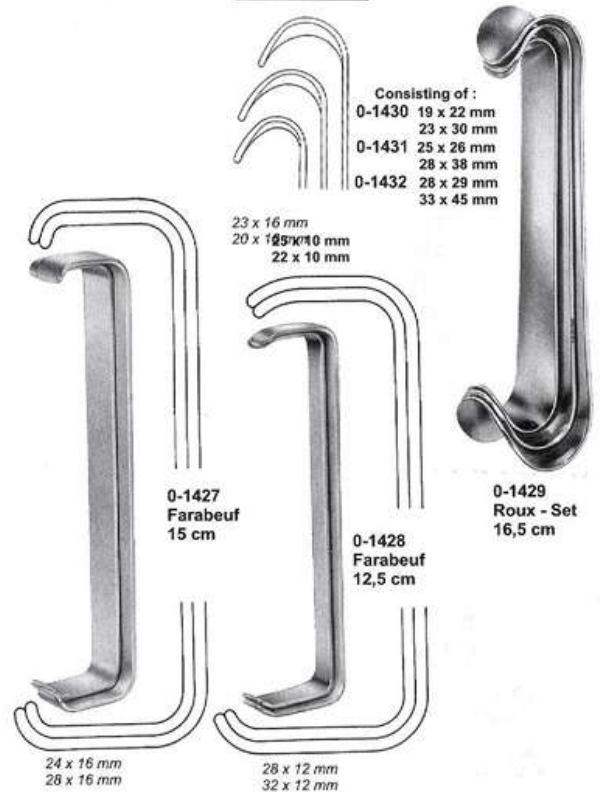

## OBSTETRICAL (Midwifery) FORCEPS



De Lee  
0-1433  
30 cm / 12"



De Lee  
0-1434 36 cm / 14"  
0-1435 39 cm / 15½"



Elliot  
0-1436 32 cm / 12½"  
0-1437 38 cm / 15"



Mc Lean  
0-1438 36 cm / 14"

## OBSTETRICAL (Midwifery) FORCEPS



Simpson-Luikart  
0-1439  
36 cm / 14"

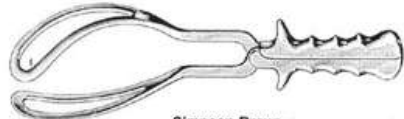

Simpson-Braun  
0-1440  
36 cm / 14"



Simpson  
0-1441  
30 cm / 12"

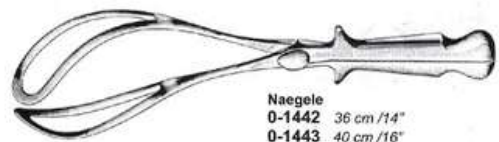

Naegle  
0-1442 36 cm / 14"  
0-1443 40 cm / 16"

51

## OBSTETRICAL (Midwifery) FORCEPS

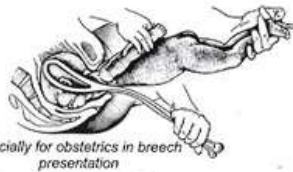

Kielland  
0-1444  
41 cm / 16"



Kielland-Luikart  
0-1445  
40 cm / 15½"



Piper  
0-1446  
44 cm / 17½"

## RETRACTORS

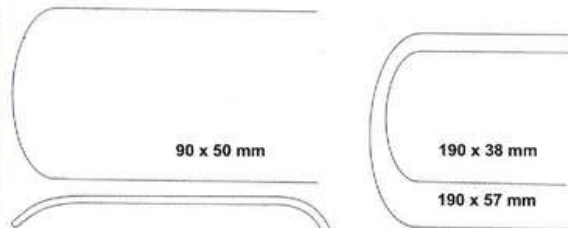

Mikulicz  
0-1447  
26cm / 10¼"



Kelly  
0-1448  
27cm / 10½"



TENACULUM FORCEPS

TENACULUM FORCEPS



Schroeder  
0-1449  
25 cm /10"

Braun  
0-1450  
25 cm /10"

Duplay  
0-1451  
28 cm /11"



Staude-Moore  
0-1452  
17 cm /6 3/4"

Barrett  
0-1453  
18 cm /7"

Pozzi  
0-1454  
25,5 cm /10 1/4"

RETRACTORS, ENDOSPECULA

TENACULUM FORCEPS

With guide blades

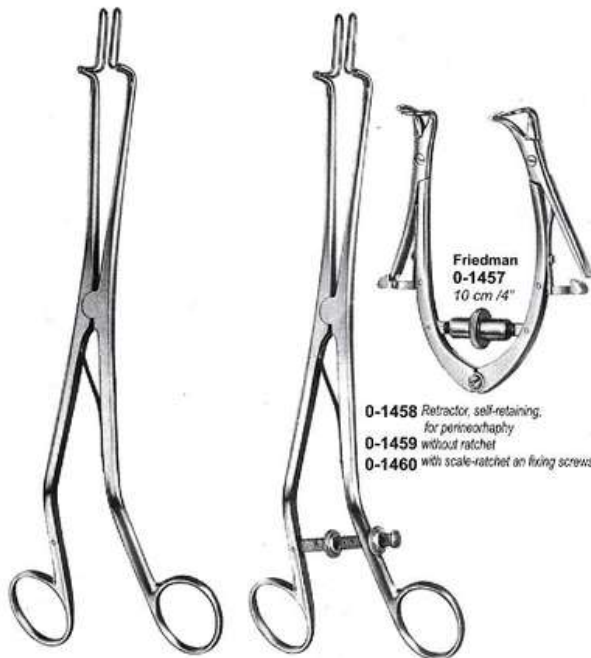

Kogan  
0-1455  
24 cm /9 1/2"

Kogan  
0-1456  
24 cm /9 1/2"

Friedman  
0-1457  
10 cm /4"

0-1458 Retractor, self-retaining,  
for perineorrhaphy  
0-1459 without ratchet  
0-1460 with scale-ratchet on fixing screws

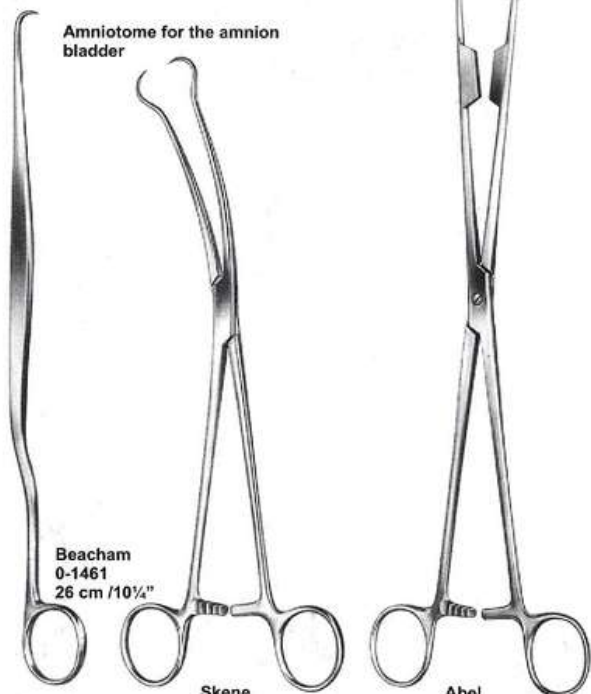

Amniotome for the amnion  
bladder

Beacham  
0-1461  
26 cm /10 1/4"

Skene  
0-1462  
24 cm /9 1/2"

Abel  
0-1463  
27 cm /10 1/2"

**DILATING BOUGIES, METAL CATHETERS**

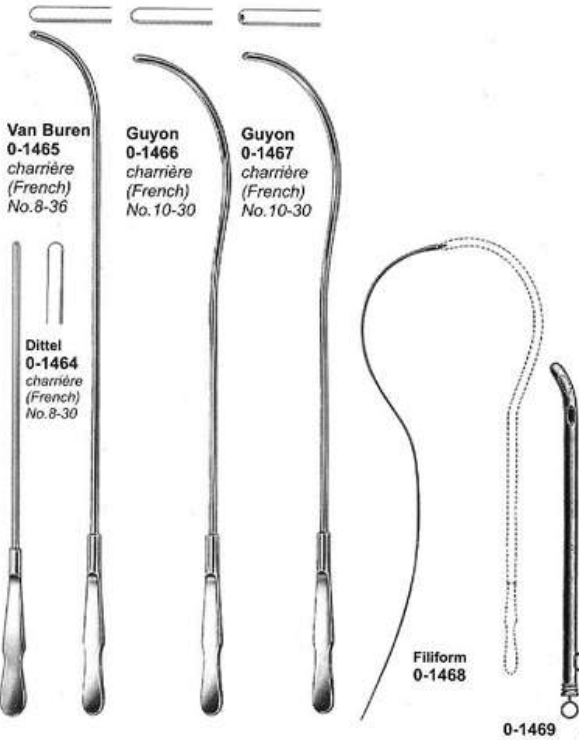

**CATHETER INTRODUCING INSTRUMENTS**

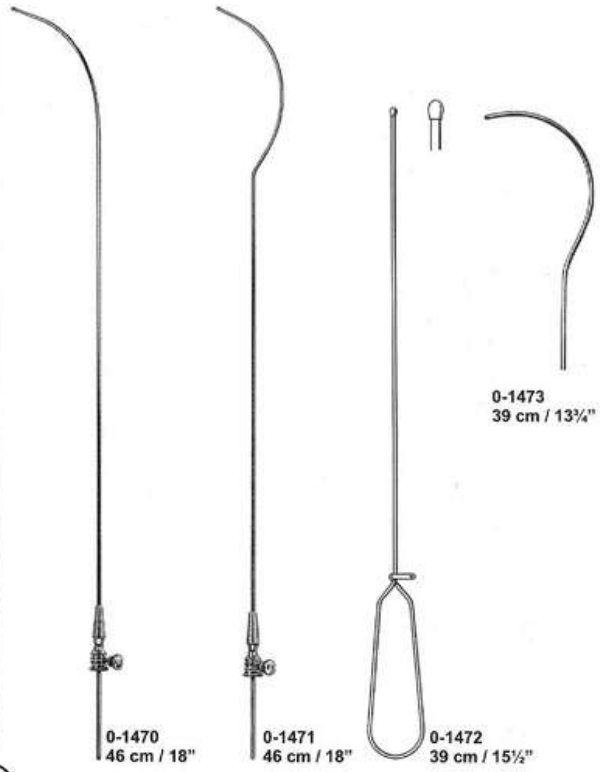

53

**MEATOTOME, SECRETION SCOOPS, PENIS SEIZING FORCEPS**

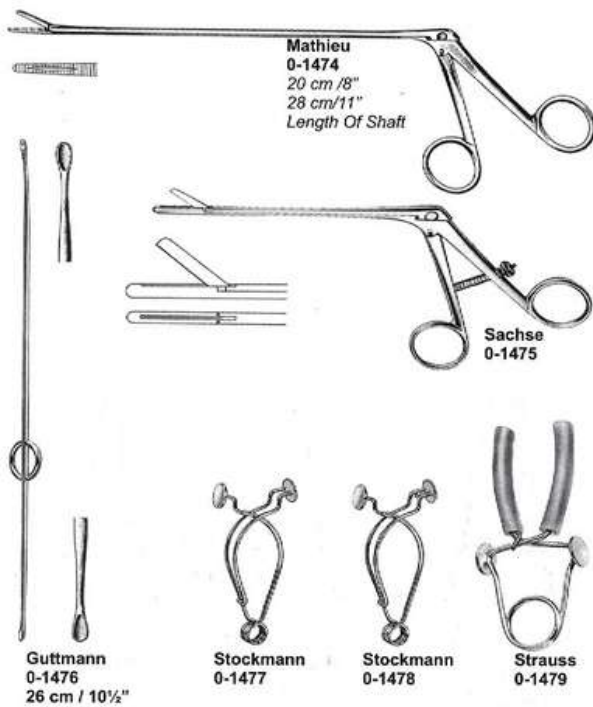

**LAMINECTOMY RONGEURS**

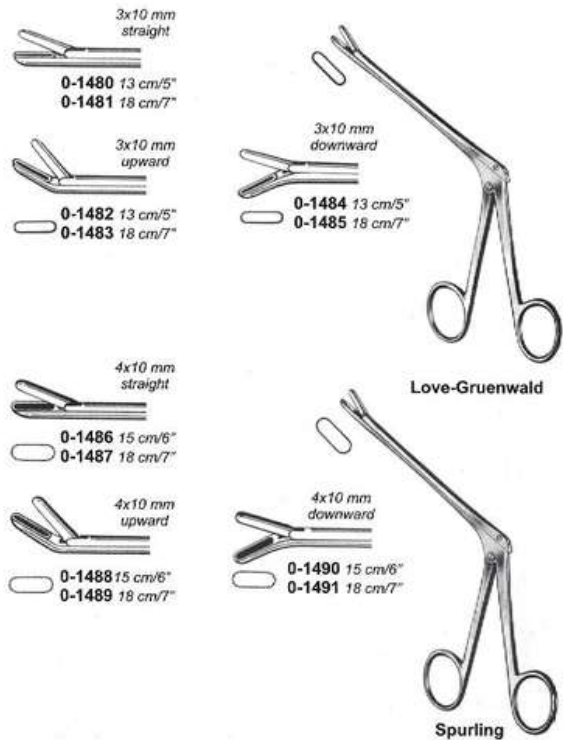

UTERINE POLYPUS FORCEPS  
& TENACULUM FORCEPS



**Museux**  
0-1492  
24 cm / 9½"

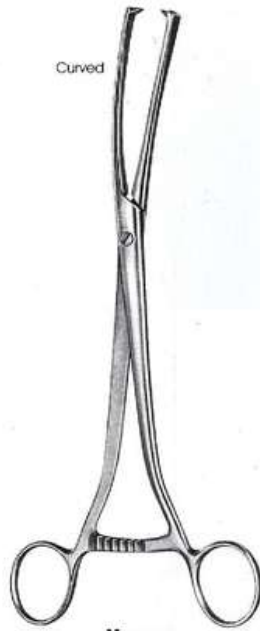

Curved

**Museux**  
0-1493  
24 cm / 9½"

UTERINE ELEVATING FORCEPS  
& TENACULUM FORCEPS



**Dartigues**  
0-1495  
27 cm / 10½"



**Somer**  
0-1496  
23 cm / 9"



**Collin**  
0-1497  
25 cm / 10"

54

UTERINE POLYPUS FORCEPS  
& TENACULUM FORCEPS



**Doyen**  
0-1498  
20 cm / 8"



**Noto**  
0-1499  
27 cm / 10½"

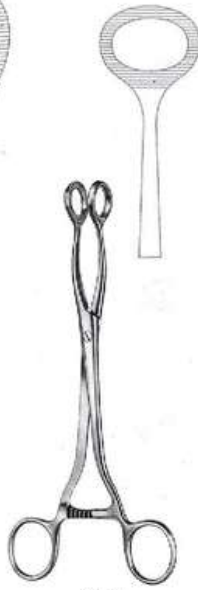

**Kelly**  
0-1500  
32 cm / 12½"

UTERINE ELEVATING FORCEPS  
& TENACULUM FORCEPS

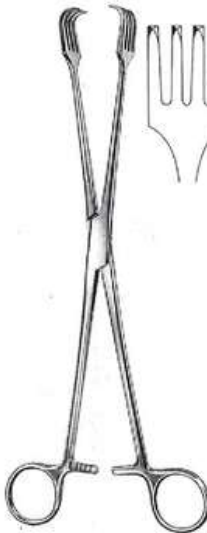

**Czerny**  
0-1501  
20.5 cm / 8¼"



**Braun**  
0-1502  
15.5 cm / 6¼"



**0-1503**  
26 cm / 10¼"



FISTULA HOOKS, CONE KNIVES

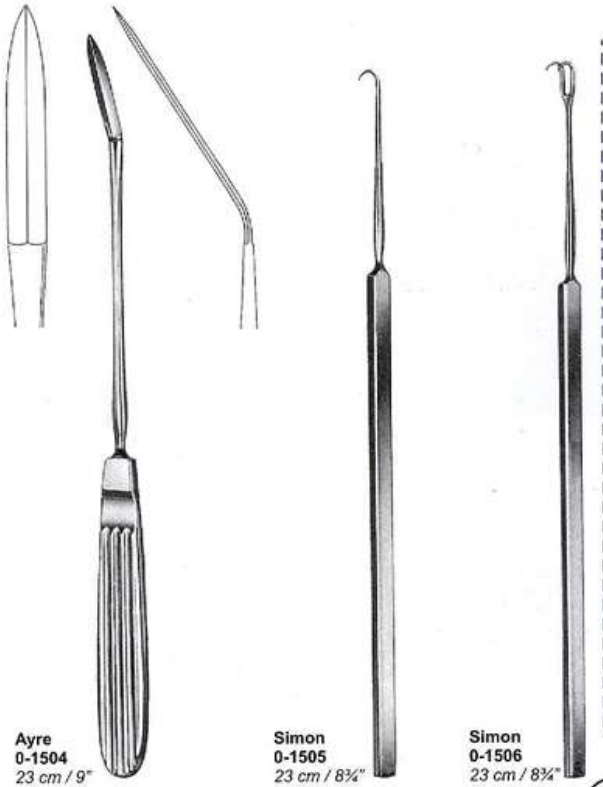

TENACULUM FORCEPS & MYOMA INSTRUMENTS

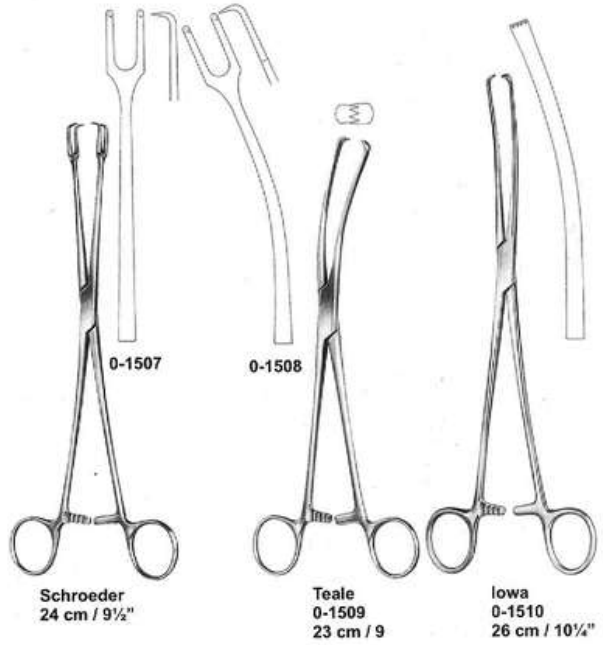

55

TENACULUM FORCEPS

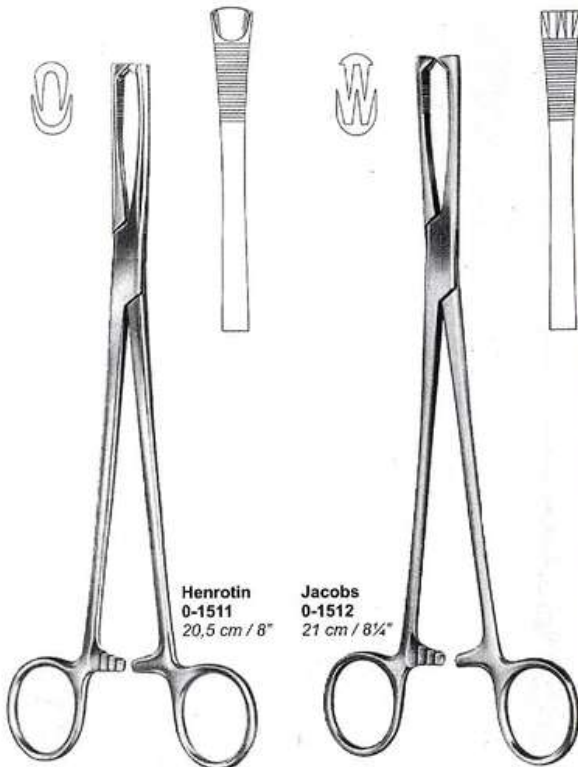

TENACULUM FORCEPS & MYOMA INSTRUMENTS

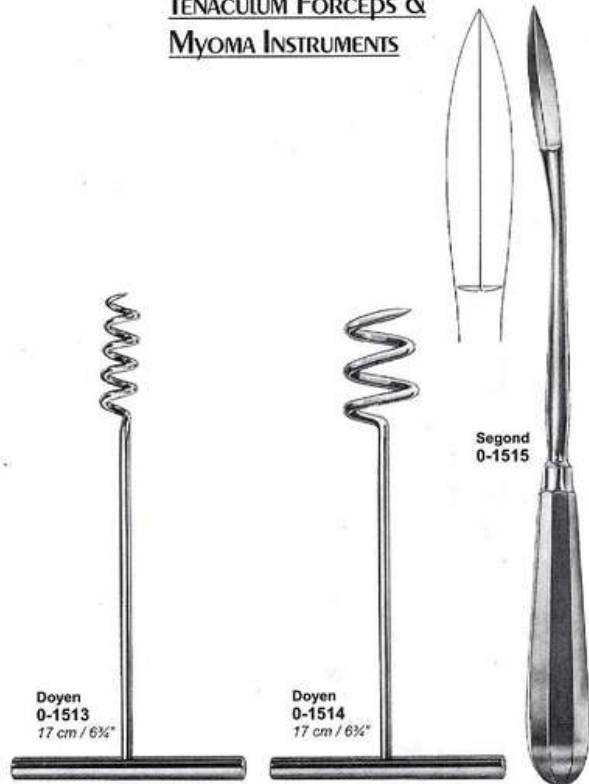

## UTERINE SOUNDS AND DEPRESSORS

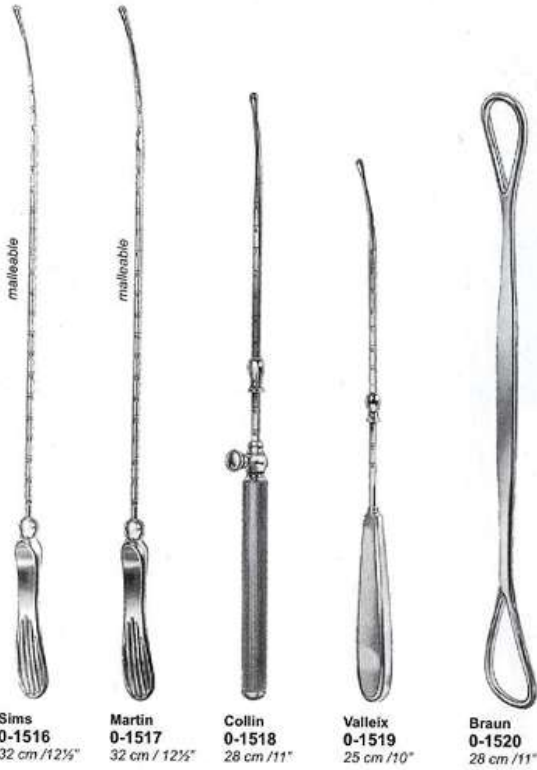

**Sims**  
0-1516  
32 cm / 12½"

**Martin**  
0-1517  
32 cm / 12½"

**Collin**  
0-1518  
28 cm / 11"

**Valleix**  
0-1519  
25 cm / 10"

**Braun**  
0-1520  
28 cm / 11"

## SUCTION BIOPSY CURETTES

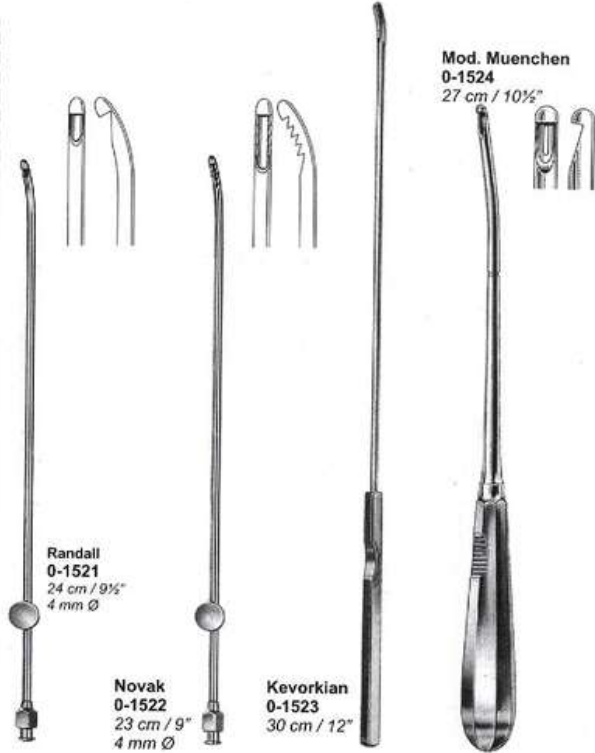

**Randall**  
0-1521  
24 cm / 9½"  
4 mm Ø

**Novak**  
0-1522  
23 cm / 9"  
4 mm Ø

**Kevorkian**  
0-1523  
30 cm / 12"

**Mod. Muenchen**  
0-1524  
27 cm / 10½"

56

## TRANSCERVICAL ASPIRATION INSTRUMENT

### Advantages

- Optimal visibility with ultrasound.
- Less traumatic because of the bulb-shaped end.
- Even when strongly flexed the obturator is extremely easy to remove.
- After removal of the obturator the catheter is still easy to manipulate in all directions.
- The placental area is easy accessible due to softness of the catheter, even in case of an unfavorable position of the uterus.
- Cost is minimal due to durability and reusability.

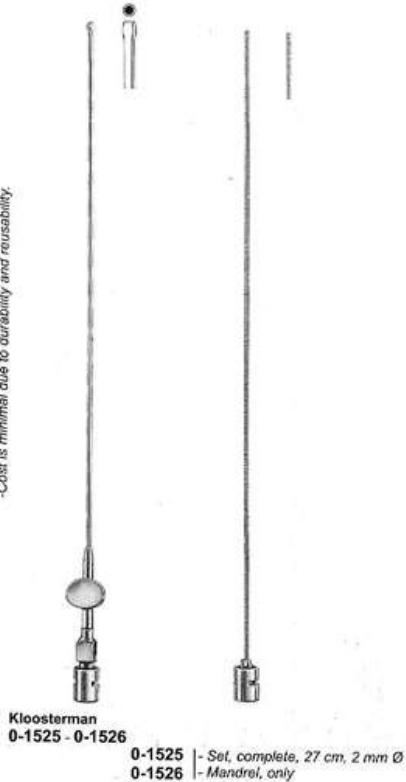

**Kloosterman**  
0-1525 - 0-1526

0-1525 - Set, complete, 27 cm, 2 mm Ø  
0-1526 - Mandrel, only

## OVUM CURETTES, ABORTION SCOOPS, CLAMPS UMBILICALES

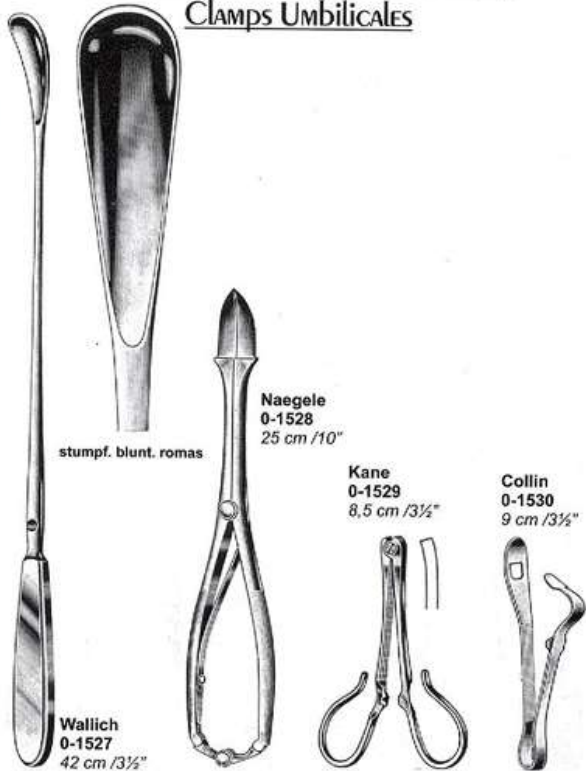

stumpf. blunt. romas

**Naegele**  
0-1528  
25 cm / 10"

**Kane**  
0-1529  
8,5 cm / 3½"

**Collin**  
0-1530  
9 cm / 3½"

**Wallich**  
0-1527  
42 cm / 3½"

**PELVIMETERS**



**Martin**  
0-1531  
34 cm / 13½"  
cm / inch scale



**Collin**  
0-1532  
35 cm / 13¾"  
cm scale



**Broisky**  
0-1533  
33 cm / 13"  
cm / inch scale

**OVUM CURETTES, ABORTION SCOOPS**



toothed back



14½ mm



18 mm



21 mm



**Cuzzi**  
30 cm / 12"

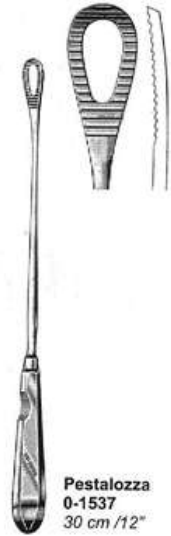

**Pestalozza**  
0-1537  
30 cm / 12"

57

**UTERINE SCOOPS**

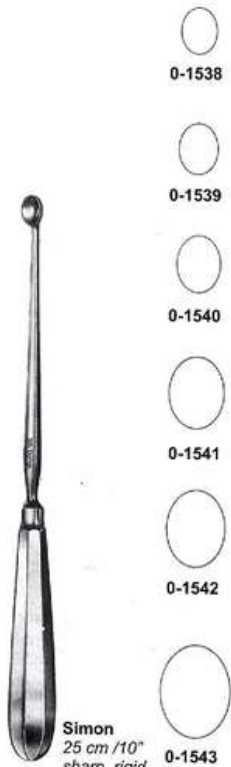

**Simon**  
25 cm / 10"  
sharp, rigid



0-1538

0-1539

0-1540

0-1541

0-1542

0-1543



**Schroeder**  
30 cm / 10"  
sharp, rigid



0-1544

0-1545

0-1546

0-1547

0-1548

0-1549

**UTERINE SCOOPS**

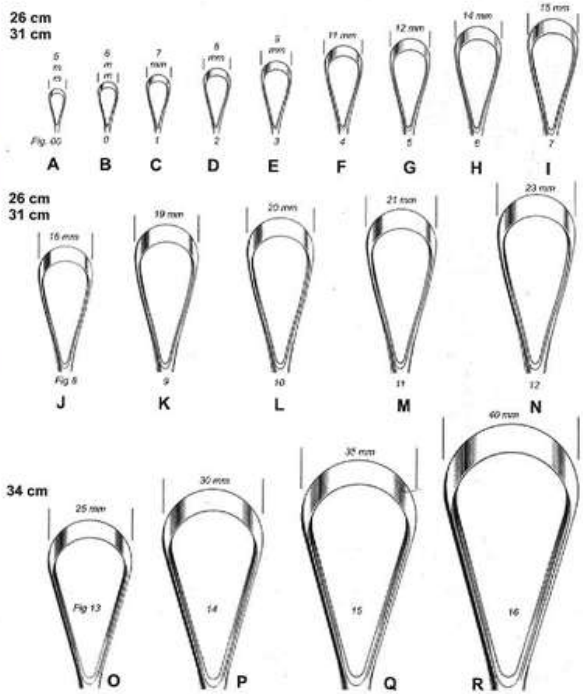

26 cm

31 cm

5 mm

6 mm

7 mm

8 mm

9 mm

11 mm

12 mm

14 mm

15 mm

16 mm

19 mm

20 mm

21 mm

23 mm

25 mm

30 mm

35 mm

40 mm

Fig. 13

Fig. 14

Fig. 15

Fig. 16

Fig. 17

Fig. 18

Fig. 19

Fig. 20

Fig. 21

Fig. 22

Fig. 23

Fig. 24

Fig. 25



**GALL STONE FORCEPS, CATCHERS,  
AND SCOOPS**

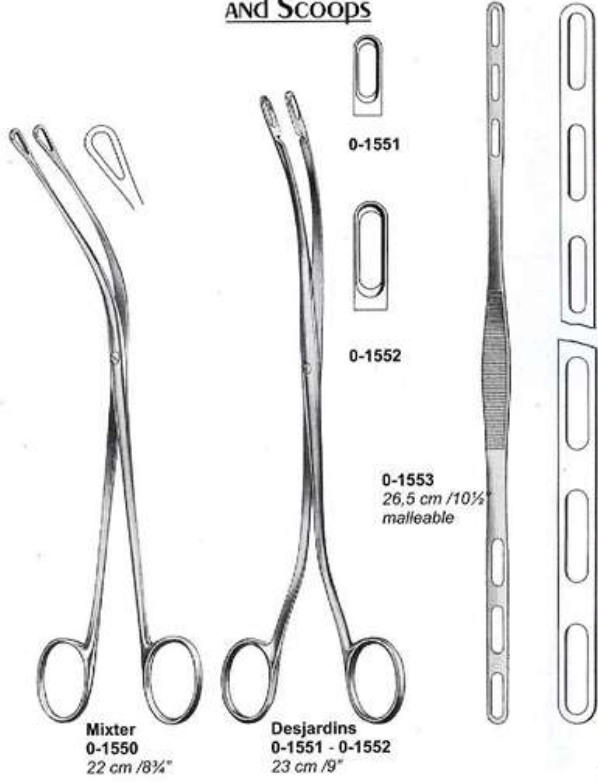

**NEPHROSTOMY FORCEPS**

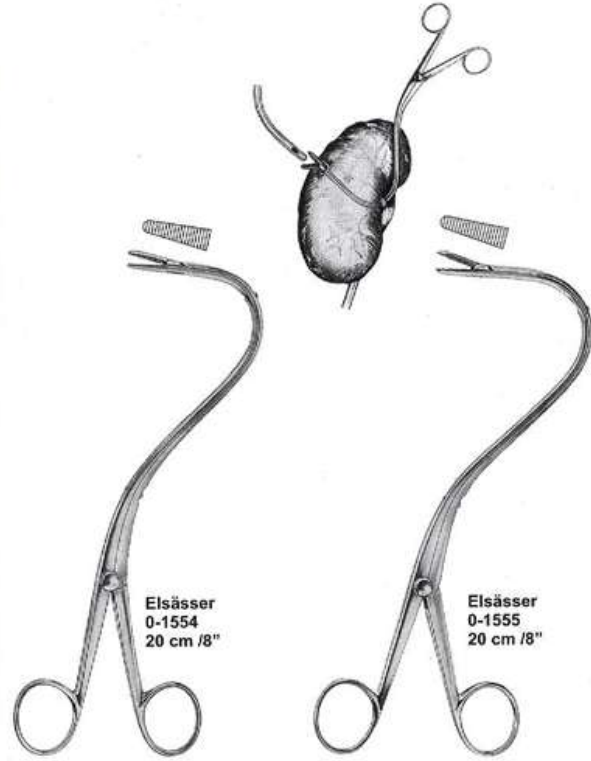

**KIDNEY FORCEPS, CATHETER INTRODUCERS**



**GALL STONE FORCEPS**

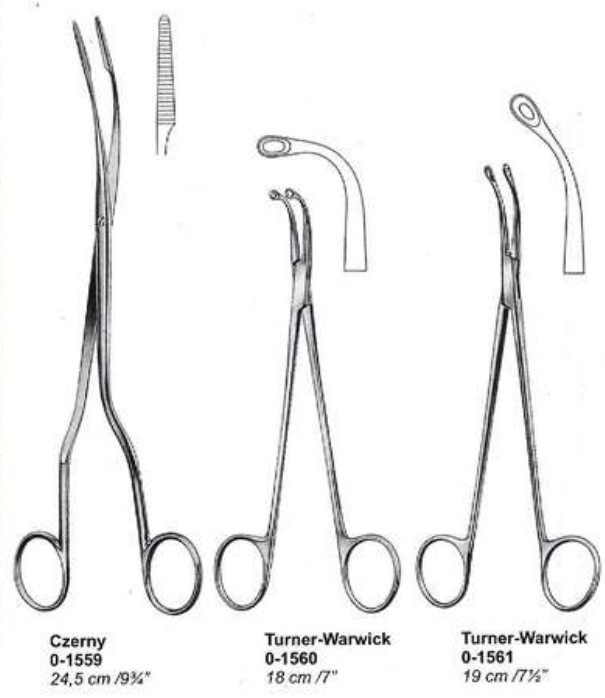

## GALL STONE SCOOPS



## GALL STONE SCOOPS

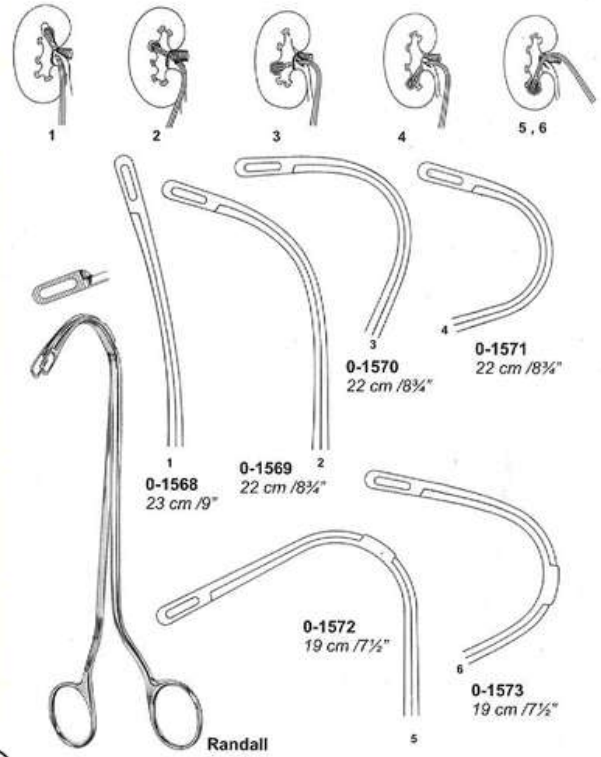

## GALL STONE SCOOPS

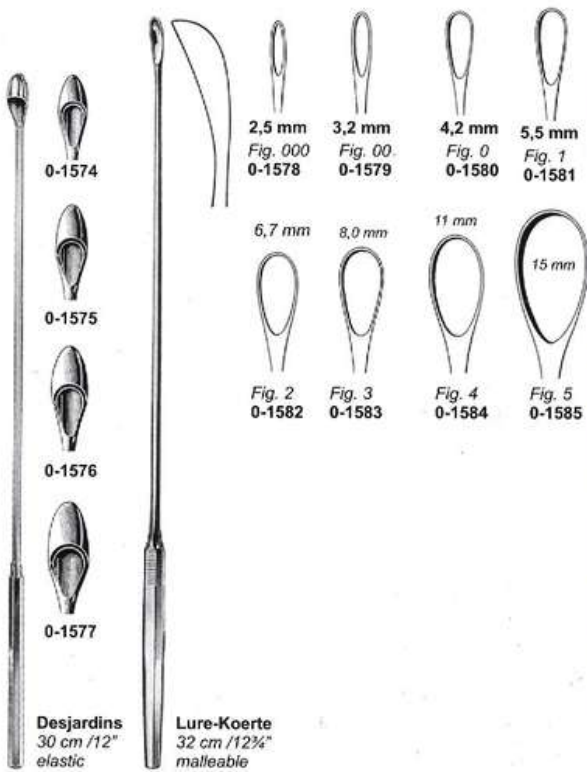

## GALL STONE PROBES, GALL DUCT DILATORS

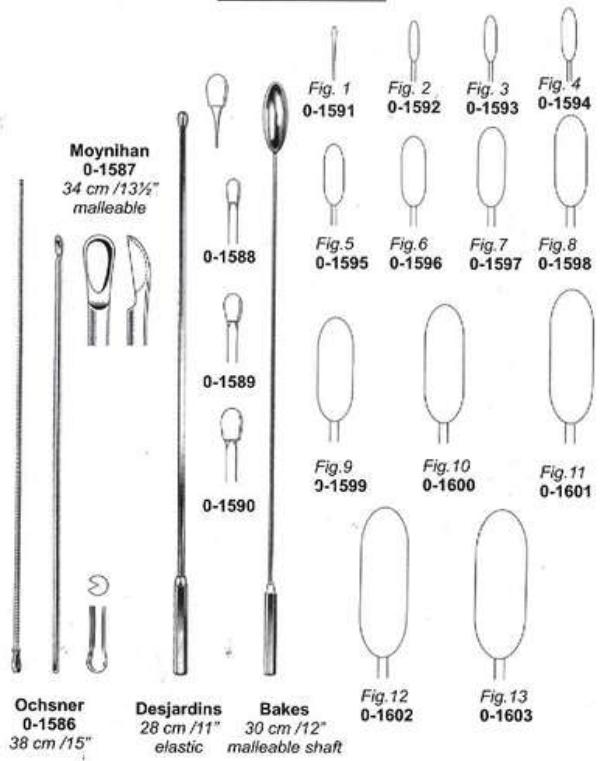

GALL STONE FORCEPS

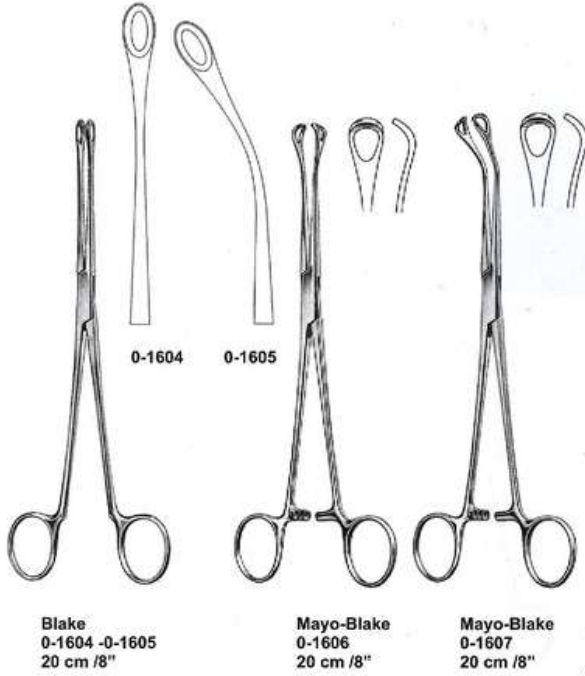

Scalp Flap Forceps, Elevating Spoon

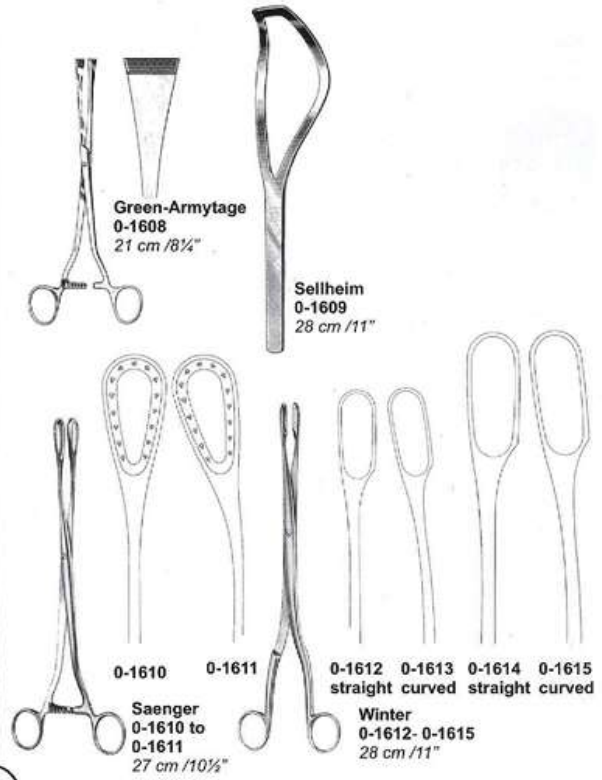

GALL STONE FORCEPS

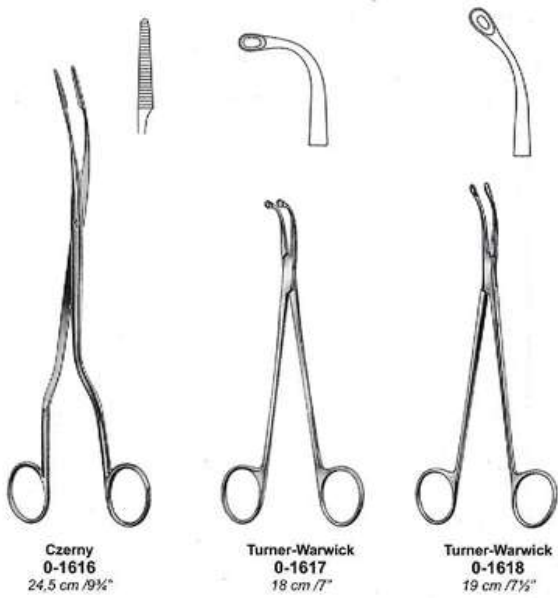

URETER CALCULUS FORCEPS





**RECTAL BIOPSY SPECIMEN FORCEPS,  
HAEMORRHOIDAL(Pile) FORCEPS**

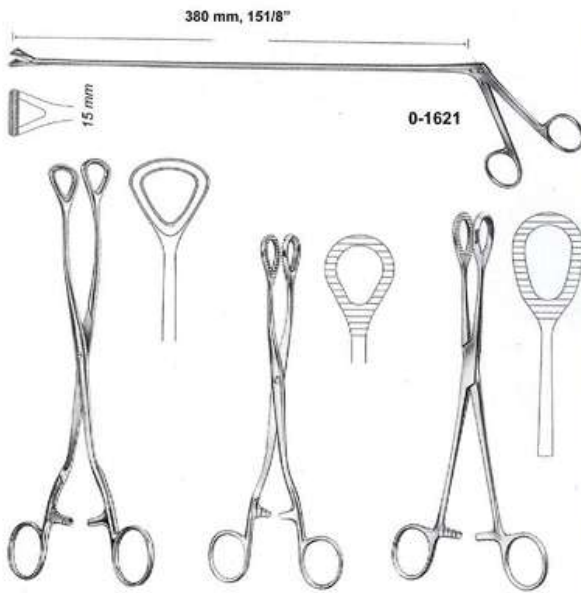

**Luer**  
0-1622  
24,5 cm /9 3/4"

**Heywood-Smith**  
0-1623  
20 cm /8"

**Heywood-Smith**  
0-1624  
21 cm /8 1/4"

**PROSTATECTOMY INSTRUMENTS**

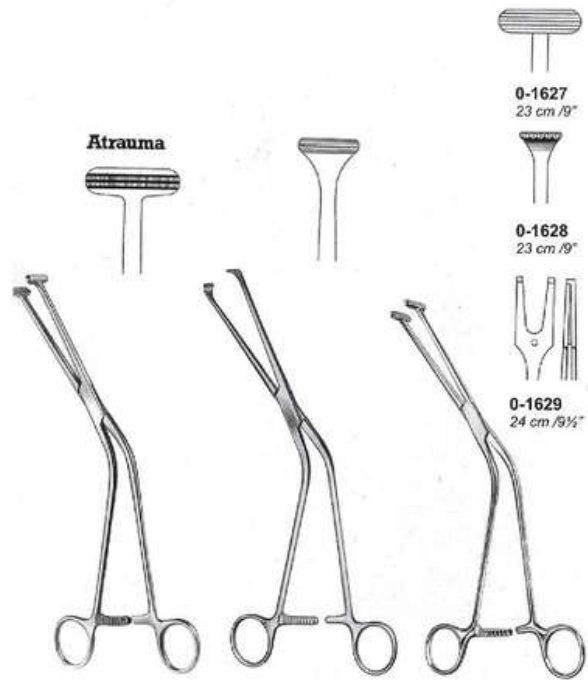

**Millin**  
0-1625  
23,5 cm /9 1/4"

**Millin**  
0-1626  
24,5 cm /9 3/4"

**Millin**  
0-1627-0-1629  
24 cm /9 1/2"

**CERVICAL BIOPSY AND SPECIMEN FORCEPS**



**Gellhorn**  
0-1630  
23 cm /9"

**Faure**  
0-1631  
21 cm /8 1/4"

**Schubert**  
0-1632  
21 cm /8 1/4"  
0-1633  
29 cm /11 1/2"

**Thoms-Gaylor**  
0-1634  
24 cm /9 1/2"

**CERVICAL BIOPSY AND SPECIMEN FORCEPS**

*Its S-shaped construction allows clear view and sharply-delineated excisions.*

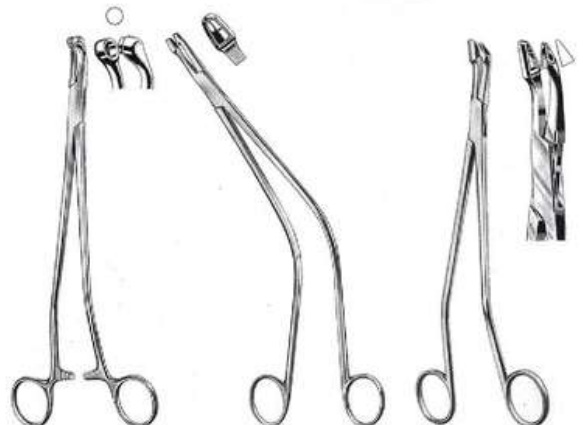

**Thoms-Gaylor**  
0-1635  
22 cm /8 1/2"  
0-1636  
24 cm /9 1/2"

**Schubert**  
0-1637  
26 cm /10 1/4"

**Van Doren**  
0-1638  
24 cm /9 1/2"

## UTERINE DilATORS

**0-1639**  
Set of 8 dilators  
3.0/4.0 - 17.0/18.0 mmØ,  
in boilable canvas roll



**0-1640**  
Set of 5 dilators



**0-1641**  
Set of 13 dilators  
1.0/2.0 - 25.0/26.0 mmØ,  
in metal case with hinged lid



**0-1642**  
Set of 15 dilators

## UTERINE DilATORS



Hank  
**0-1643**  
Set of 6

American  
Socle

Hank  
**0-1644**  
to  
**0-1649**



Hank  
Fig. 9/10 **0-1644** 4,5-5 mm  
Fig. 11/12 **0-1645** 5,5/6 mm  
Fig. 13/14 **0-1646** 6,5/7 mm  
Fig. 15/16 **0-1647** 7,5/8 mm  
Fig. 17/18 **0-1648** 8,5/9 mm  
Fig. 19/20 **0-1649** 9,5/10 mm

Hank  
**0-1650**  
Set of 6

62

## UTERINE DilATORS

**0-1651** Set of 14 dilators  
(4,0 - 17,0 Ø), in metal case with hinged lid

**0-1652** Set of 26 dilators  
(1,0 - 26,0 mm Ø), in metal case hinged lid

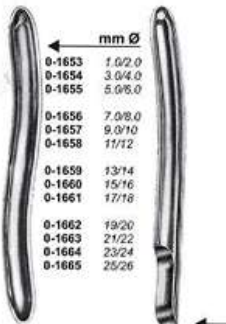

mm Ø

0-1653	1,0/2,0
0-1654	3,0/4,0
0-1655	5,0/6,0
0-1656	7,0/8,0
0-1657	9,0/10
0-1658	11/12
0-1659	13/14
0-1660	15/16
0-1661	17/18
0-1662	19/20
0-1663	21/22
0-1664	23/24
0-1665	25/26

Pieces per set	Set
14	0-1666
26	0-1667



**0-1668**  
Set of 8 dilators 3.0/4.0 - 17.0/18.0 mmØ  
**0-1669**  
Set of 13 dilators 1.0/2.0 - 25.0/26.0 mmØ

## UTERINE

Sharp

Blunt

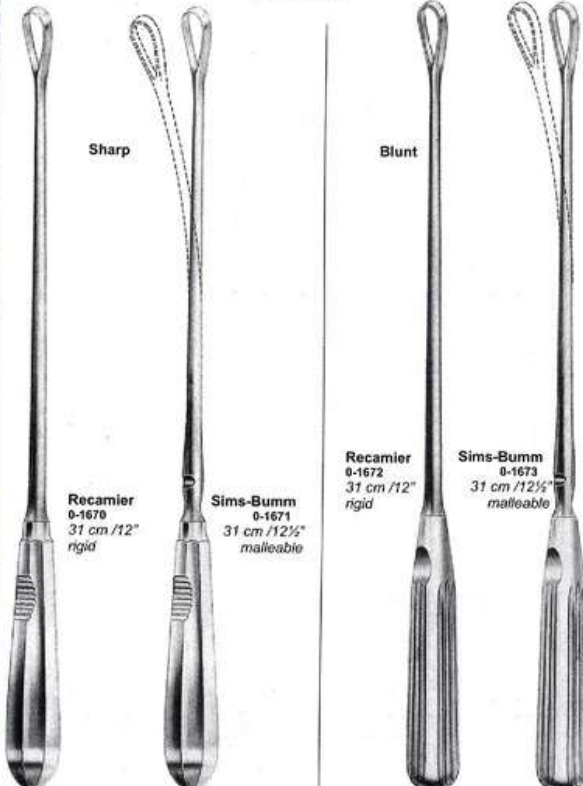

Recamier  
0-1670  
31 cm /12"  
rigid

Sims-Bumm  
0-1671  
31 cm /12 1/2"  
malleable

Recamier  
0-1672  
31 cm /12"  
rigid

Sims-Bumm  
0-1673  
31 cm /12 1/2"  
malleable

**ATRAUMA SIGMOID  
ANASTOMOSIS FORCEPS**

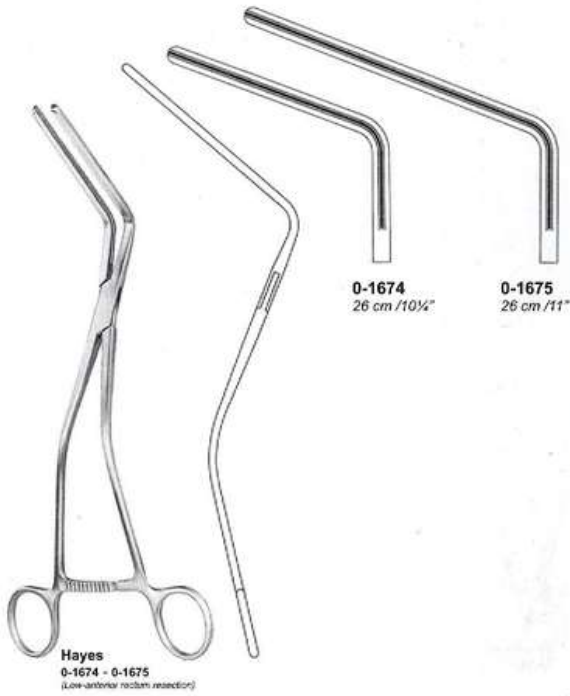

63

**ATRAUMA SIGMOID  
ANASTOMOSIS FORCEPS**



**ATRAUMA INTESTINAL AND STOMACH CLAMP  
FORCEPS, WITH MARTIN SERRATIONS**

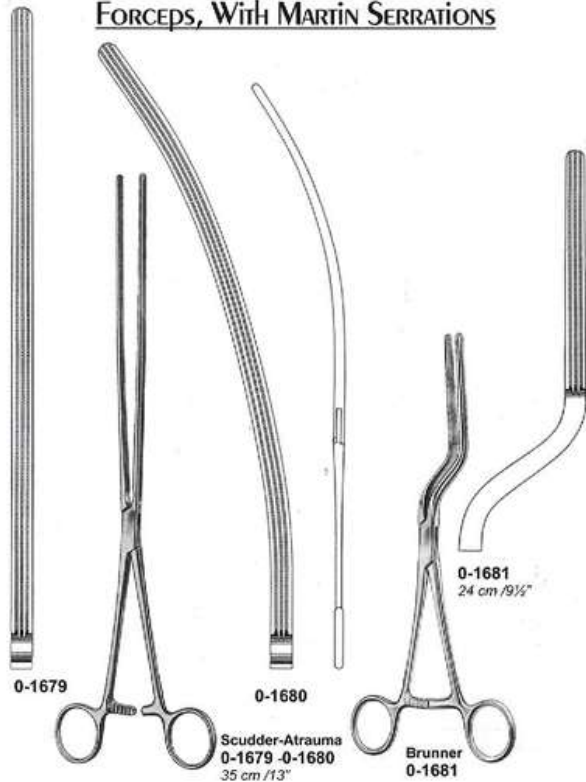



**ATRAUMA INTESTINAL AND STOMACH CLAMP  
FORCEPS, WITH MARTIN SERRATIONS**

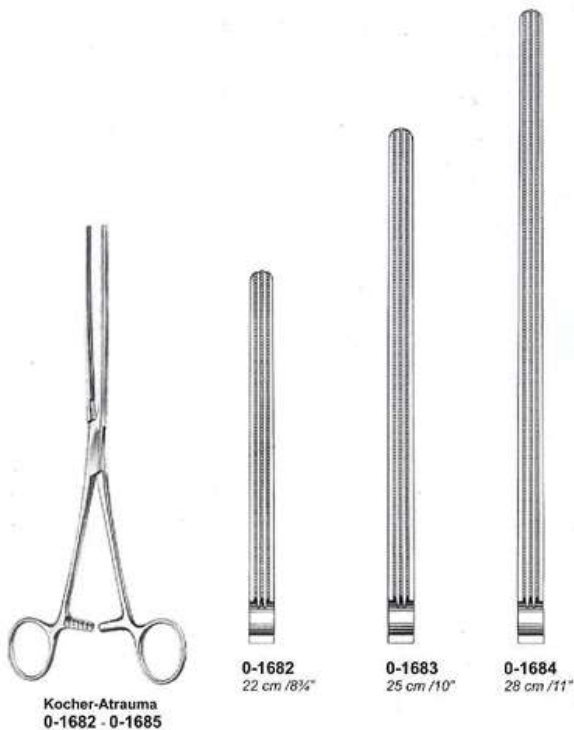

**ATRAUMA INTESTINAL AND STOMACH CLAMP  
FORCEPS, WITH MARTIN SERRATIONS**

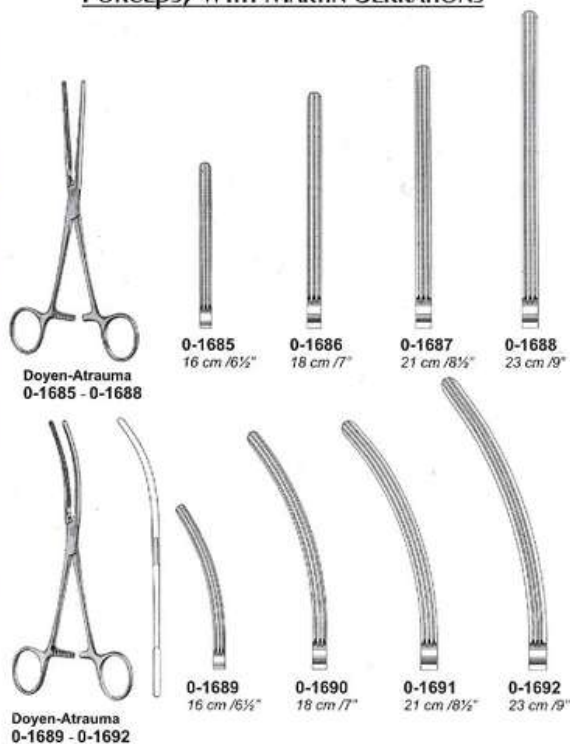

**ATRAUMA INTESTINAL AND STOMACH CLAMP  
FORCEPS, WITH MARTIN SERRATIONS**

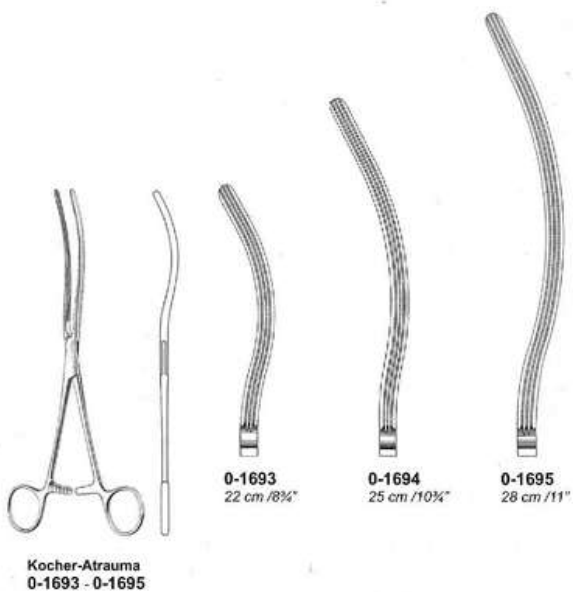

**ATRAUMA INTESTINAL AND STOMACH CLAMP  
FORCEPS, WITH MARTIN SERRATIONS**

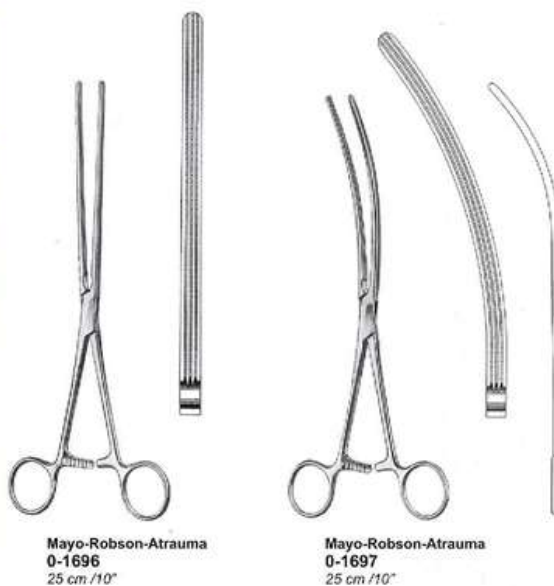

## ASPIRATING CURETTES



## SEPTUM COMPRESSION FORCEPS

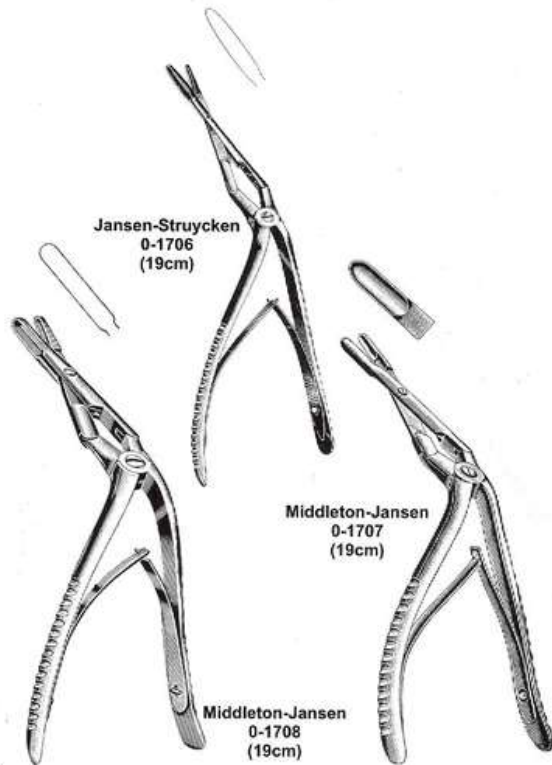

65

## BRONCHUS FORCEPS, LIGATURE FORCEPS

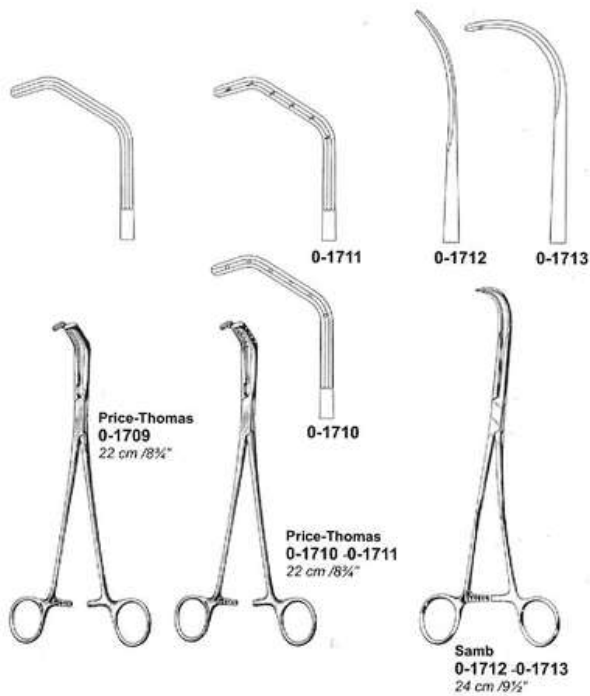

## LAMINA SPREADERS

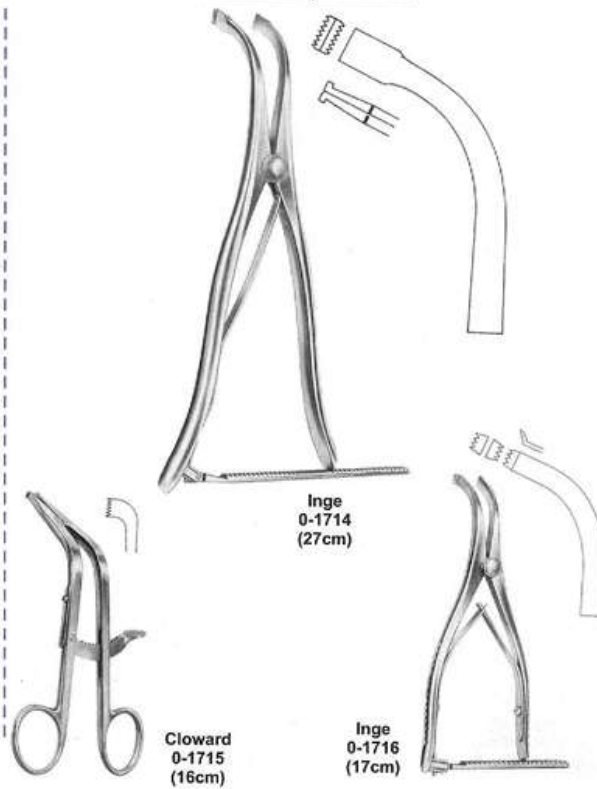

**ANTRUM PUNCH FORCEPS**  
**SPHENOID PUNCHES**



**Hajek-Claus**  
0-1717  
(20cm)

**Kerrison**  
0-1718 to 0-1720  
(20cm)

**BONE PUNCHES**

**ATTICUS PUNCHES**



**Beyer**  
0-1721  
16 cm/6 1/4"

**Beyer**  
0-1722  
19 cm/7 1/2"

**Citelli**  
17 cm/6 1/4"  
0-1723 2 mm  
0-1724 3 mm

**Clips Applying FORCEPS**



**OlivecronToennis (Scoville)**  
0-1725

**McKenzie**  
0-1726 (15cm)  
0-1727 (19cm)

**McKenzie**  
0-1728 (15cm)  
0-1729 (19cm)

**Raney**  
0-1730

**TISSUE & ORGAN HOLDING FORCEPS**

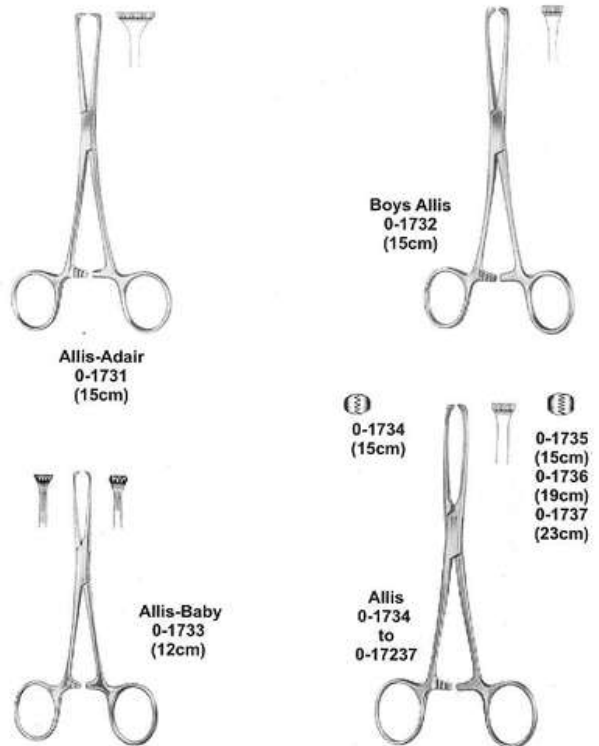

**Allis-Adair**  
0-1731  
(15cm)

**Boys Allis**  
0-1732  
(15cm)

**Allis-Baby**  
0-1733  
(12cm)

③  
0-1734  
(15cm)

④  
0-1735 (15cm)  
0-1736 (19cm)  
0-1737 (23cm)

**Allis**  
0-1734  
to  
0-17237



## CERVICAL BIOPSY & SPECIMEN FORCEPS

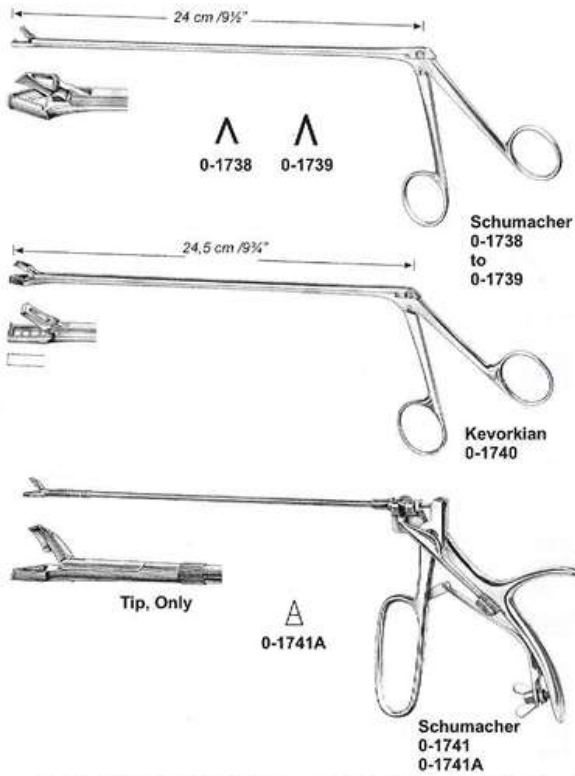

## CERVICAL BIOPSY & SPECIMEN FORCEPS

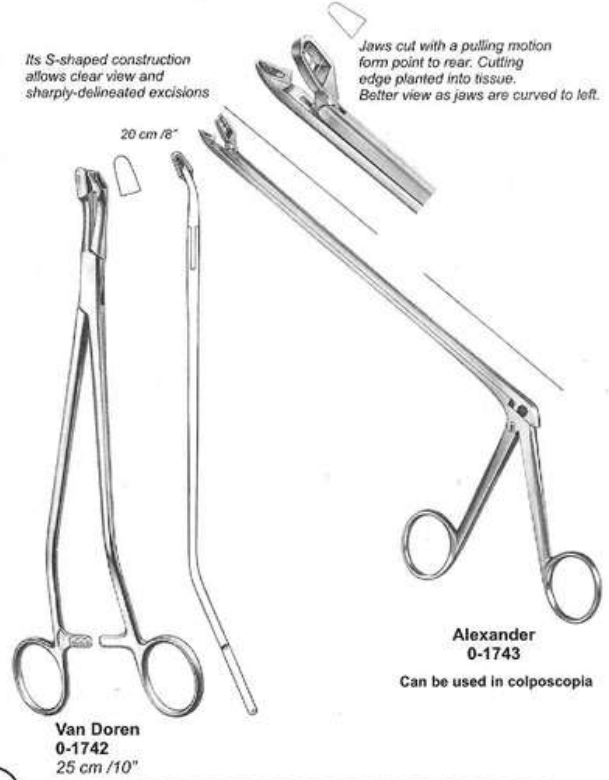

67

## PUNCHES & RONGEUR

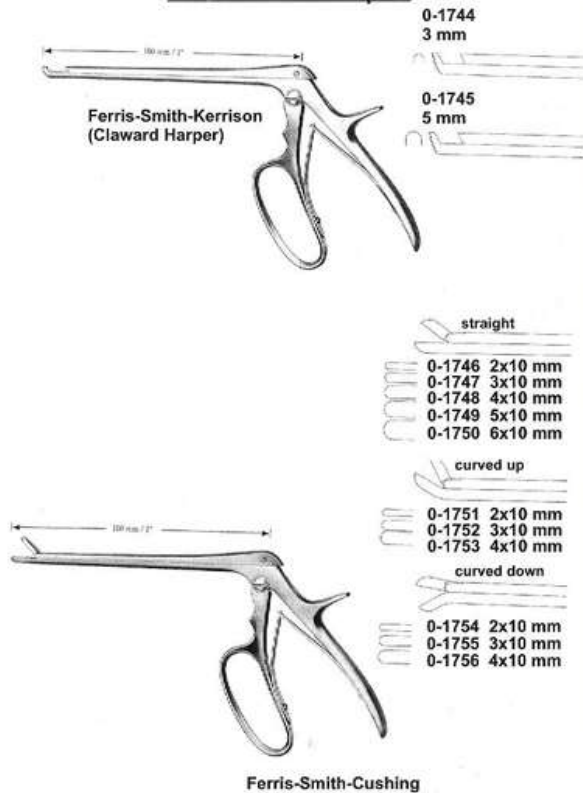

## CERVICAL BIOPSY & SPECIMEN FORCEPS

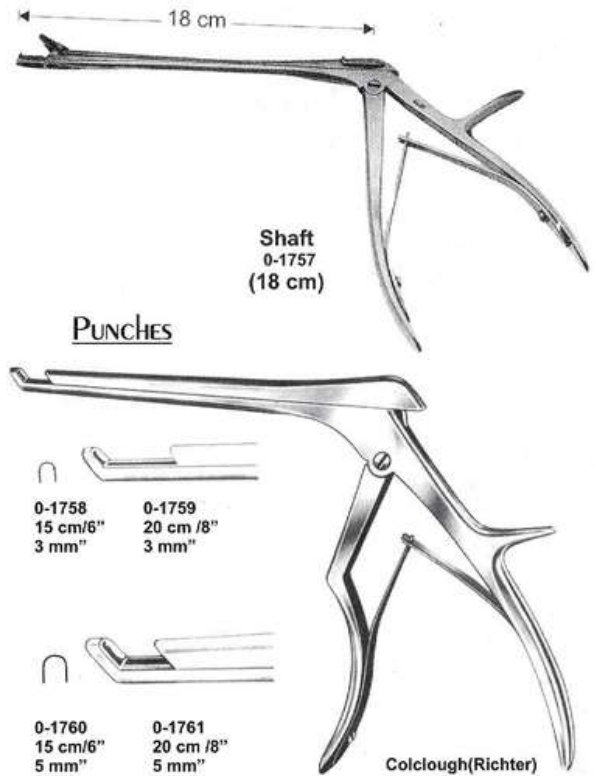

## LAMINECTOMY PUNCHES

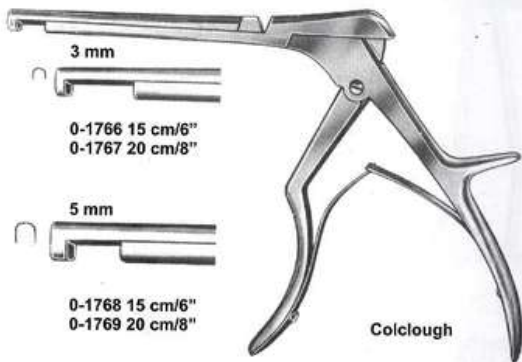
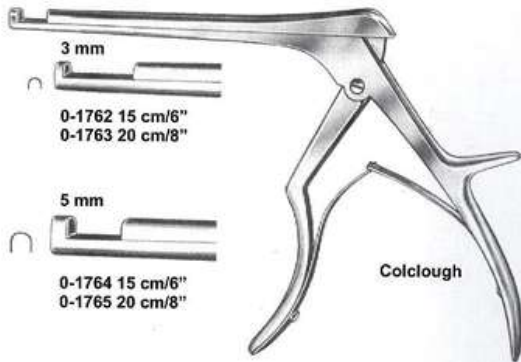

## LAMINECTOMY PUNCHES

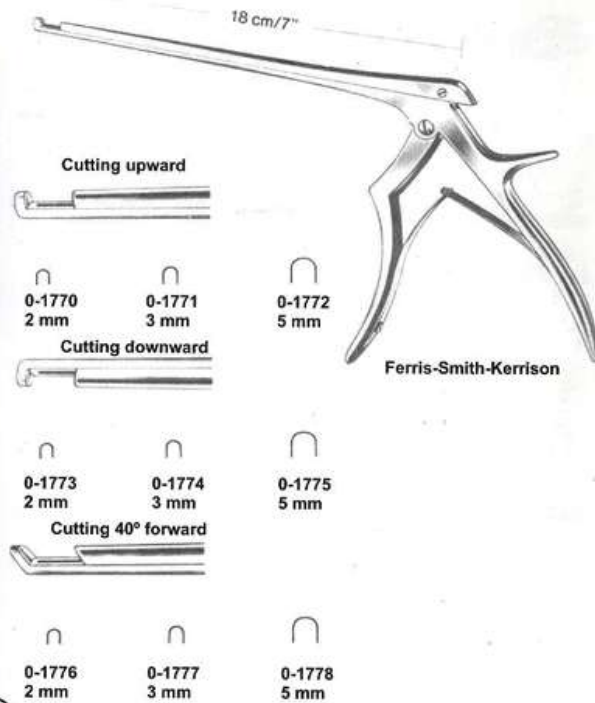

68

## LAMINECTOMY RONGEUR

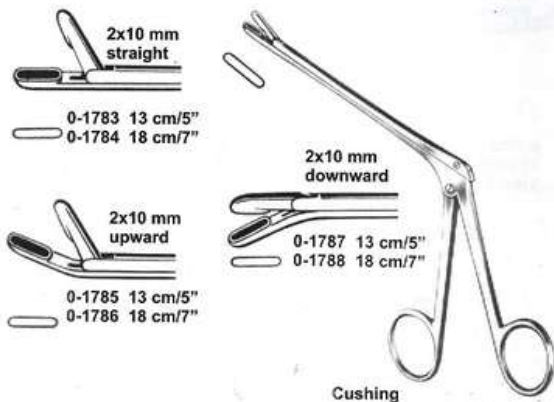
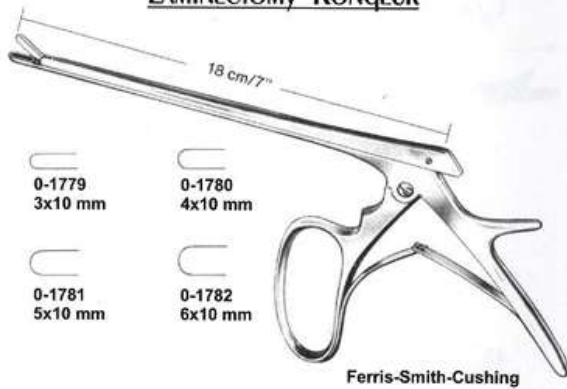

## PUNCHES

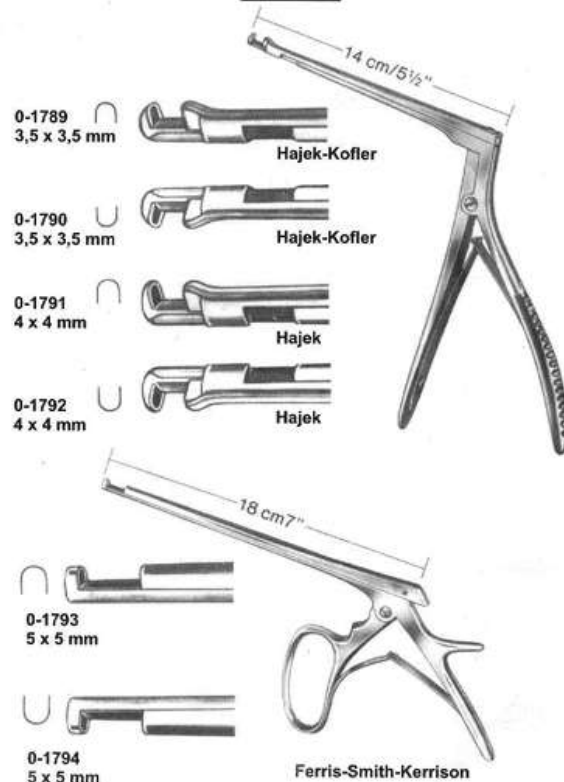

BONE CURETTES



Fig.000

Fig.00

Fig.0

Fig.1

Fig.2

Fig.3

Fig.4

Scheide  
0-1795  
000 to Fig.4

BONE CURETTES



Fig.0000

Fig.000

Fig.0

Fig.0

Fig.1

Fig.2

Fig.3

Fig.4

Fig.5

Fig.6

Volkman  
0-1796  
0000 to Fig.6

BONE CURETTES



Fig.0000

Fig.000

Fig.00

Fig.0

Fig.1

Fig.2

Fig.3

Fig.4

Fig.5

Fig.6

Bruns  
0-1797  
0000 to Fig.6

BONE CURETTES



Fig.0000

Fig.000

Fig.00

Fig.0

Fig.1

Fig.2

Fig.3

Fig.4

Fig.5

Spratt  
0-1798  
0000 to Fig.5



**PLASTER SHEARS, BANDAGE & Utility Scissors**



**PLASTER CAST INSTRUMENTS  
PLASTER KNIVES, SAWS**

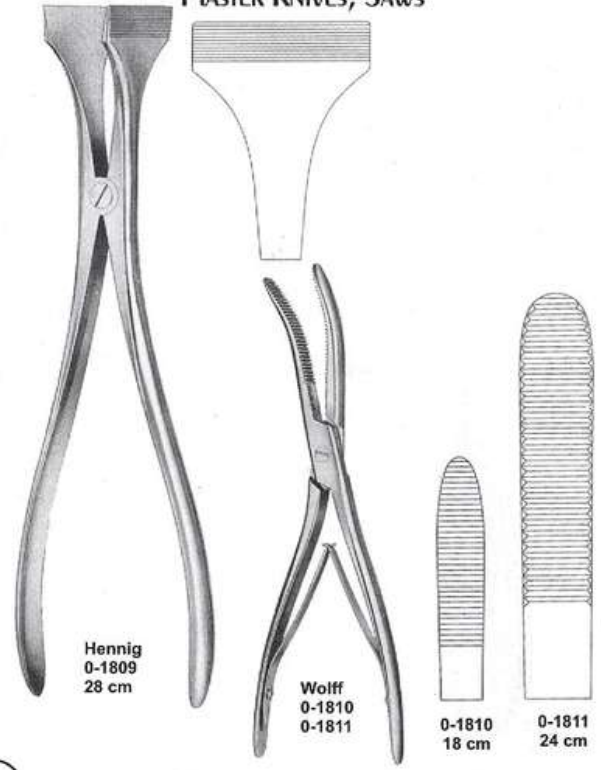

70

**BONE Holding Clamps  
AMPUTATING & RESECTION SAWS**

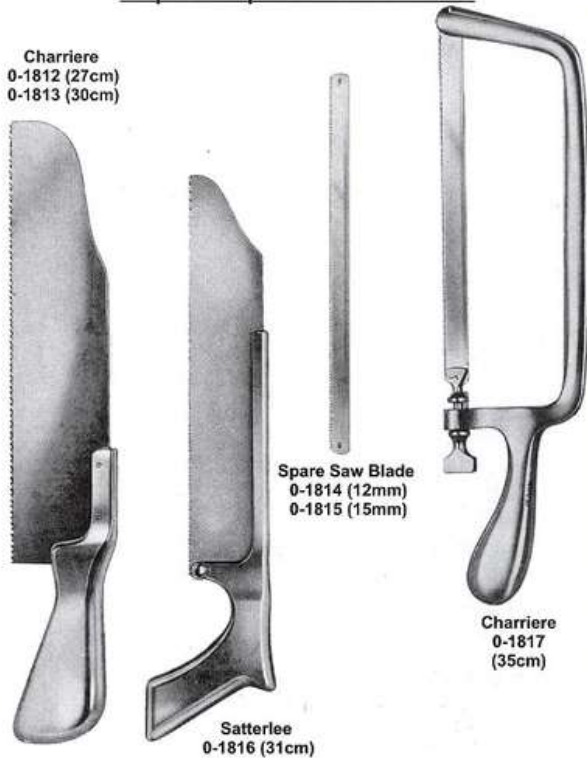

**PLASTER CAST INSTRUMENTS, KNIVES, SAWS**

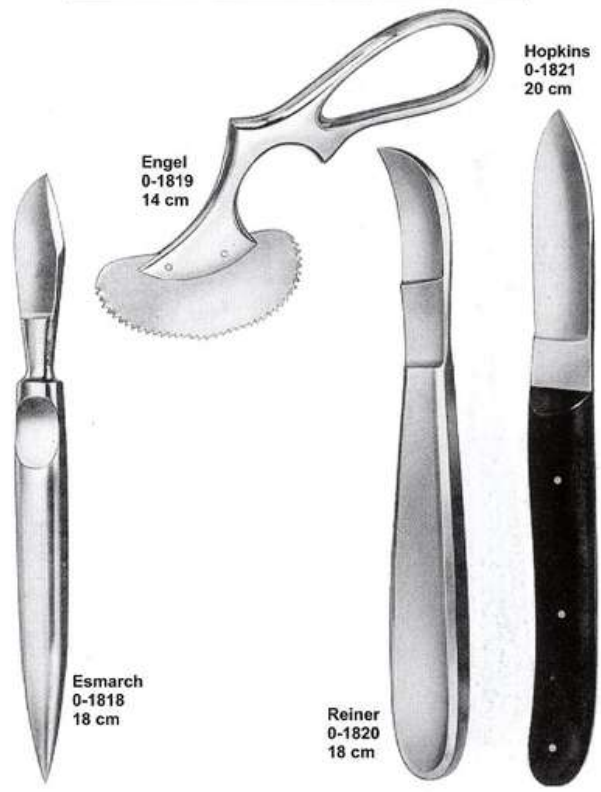

**BONE HOLDING FORCEPS**

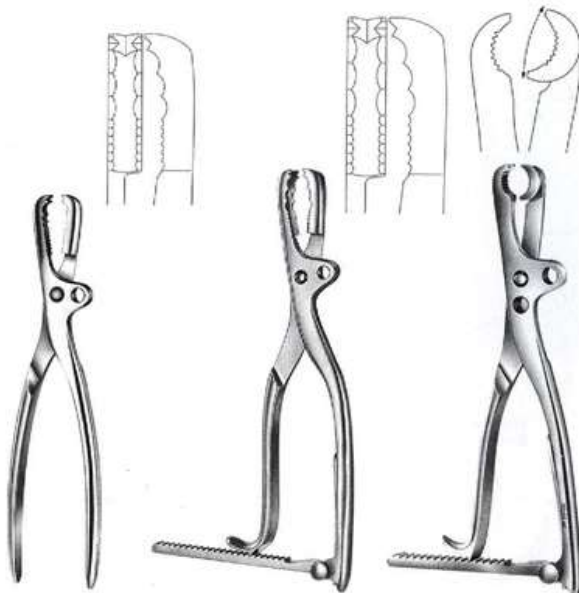

Farabeuf  
0-1840  
23cm/9"  
0-1841  
26cm/10½"

Farabeuf-Lambotte  
0-1842  
26cm/10½"

Tuffier  
0-1843  
27cm/10½"

**BONE HOLDING FORCEPS**

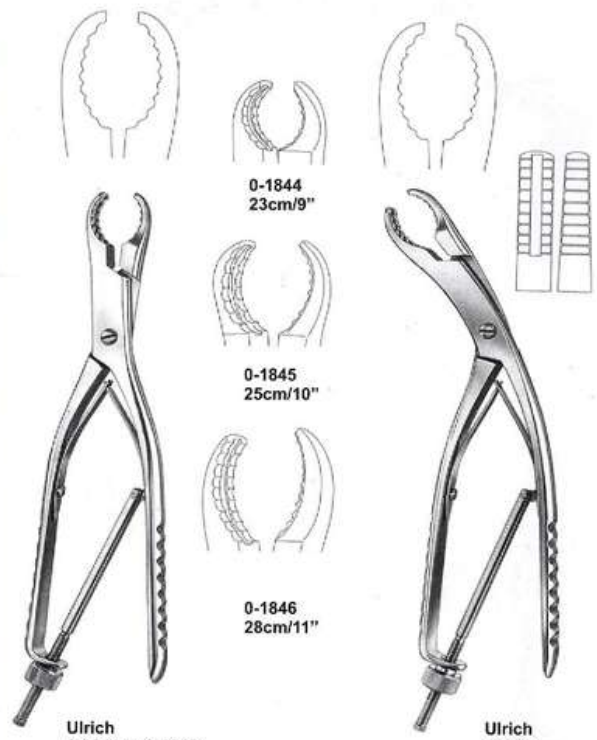

0-1844  
23cm/9"

0-1845  
25cm/10"

0-1846  
28cm/11"

Ulrich  
0-1844 to 0-1846

Ulrich  
0-1847

**BONE LEVERS**

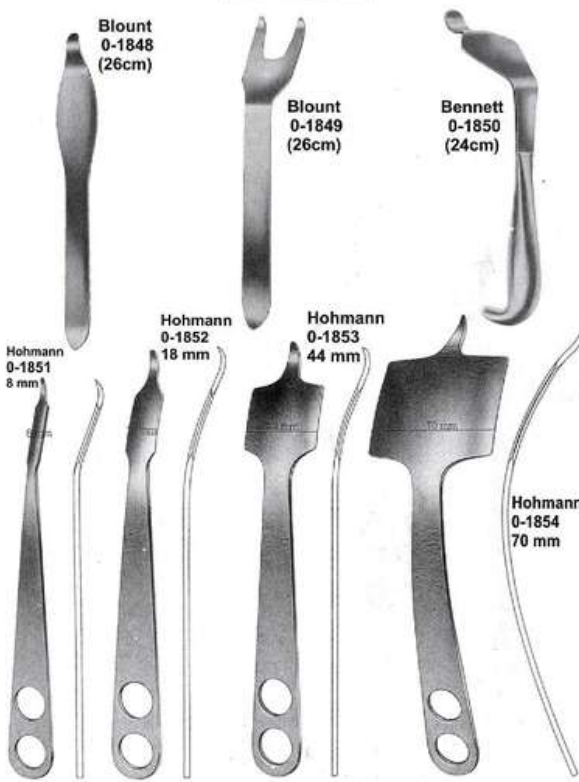

Blount  
0-1848  
(26cm)

Blount  
0-1849  
(26cm)

Bennett  
0-1850  
(24cm)

Hohmann  
0-1851  
8 mm

Hohmann  
0-1852  
18 mm

Hohmann  
0-1853  
44 mm

Hohmann  
0-1854  
70 mm

**FLAT NOSE PLIERS**



0-1855  
16 cm / 6¼"

0-1856  
to  
0-1857  
17 cm / 6¾"

0-1858  
18 cm / 7"

**BONE HOLDING FORCEPS**



Farabeuf  
0-1840  
23cm/9"  
0-1841  
26cm/10½"

Farabeuf-Lambotte  
0-1842  
26cm/10½"

Tuffier  
0-1843  
27cm/10½"

**BONE HOLDING FORCEPS**

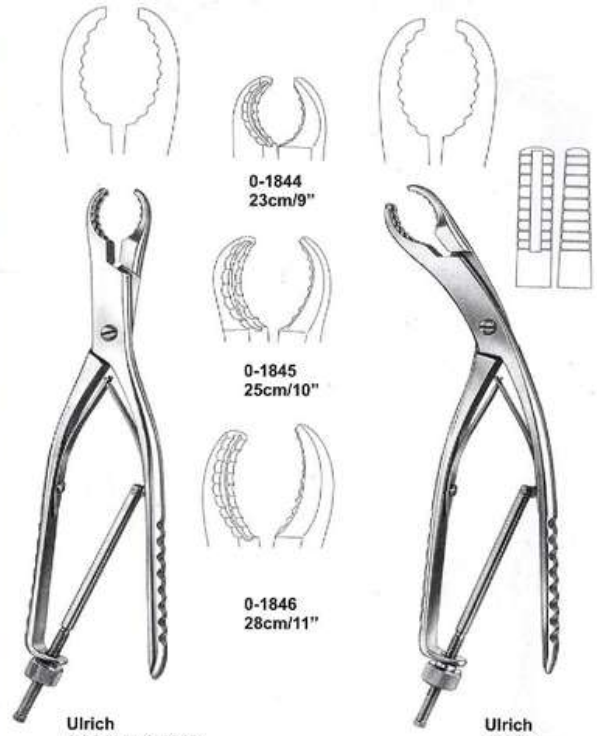

0-1844  
23cm/9"

0-1845  
25cm/10"

0-1846  
28cm/11"

Ulrich  
0-1844 to 0-1846

Ulrich  
0-1847

**BONE LEVERS**

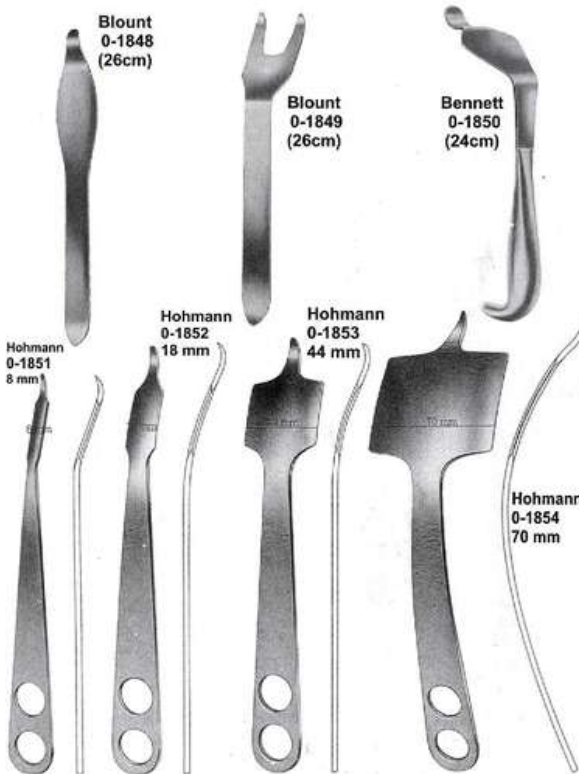

Blount  
0-1848  
(26cm)

Blount  
0-1849  
(26cm)

Bennett  
0-1850  
(24cm)

Hohmann  
0-1851  
8 mm

Hohmann  
0-1852  
18 mm

Hohmann  
0-1853  
44 mm

Hohmann  
0-1854  
70 mm

**FLAT NOSE PLIERS**



0-1855  
16 cm / 6¼"

0-1856  
to  
0-1857  
17 cm / 6¾"

0-1858  
18 cm / 7"



**BONE RONGEUR FORCEPS**

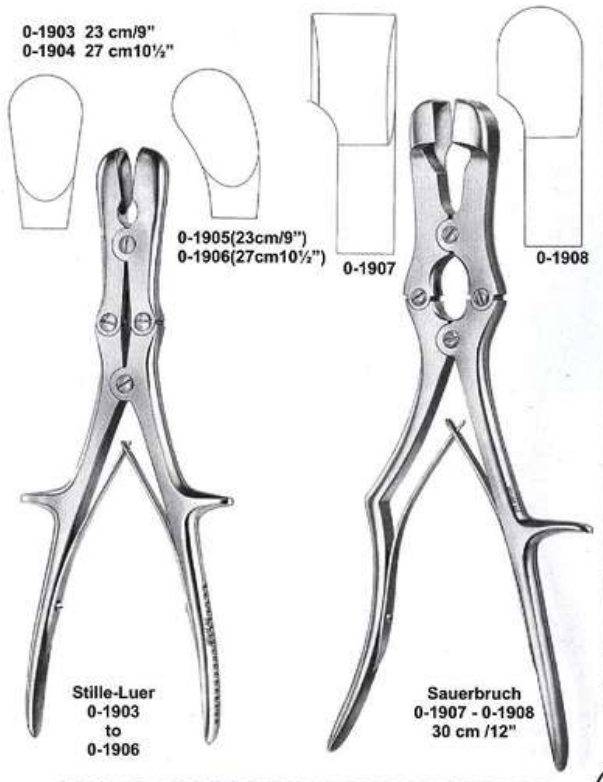

**BONE CUTTING FORCEPS**

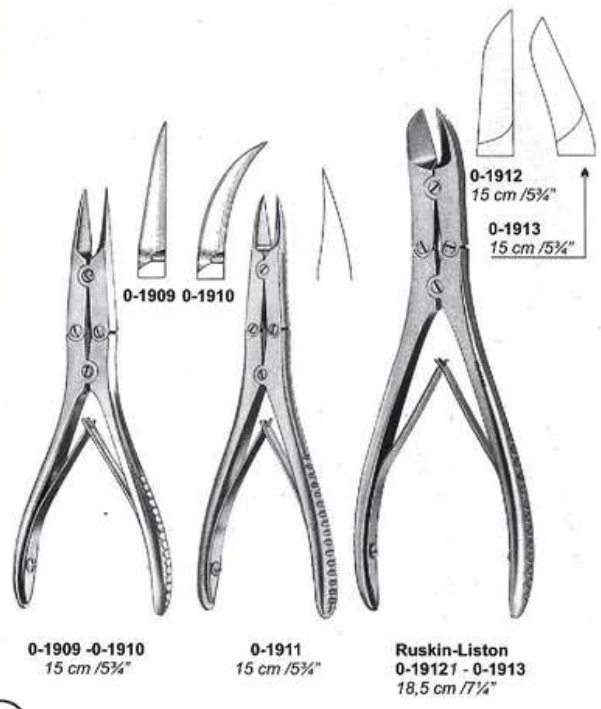

**BONE CUTTING FORCEPS**



**BONE CUTTING FORCEPS**

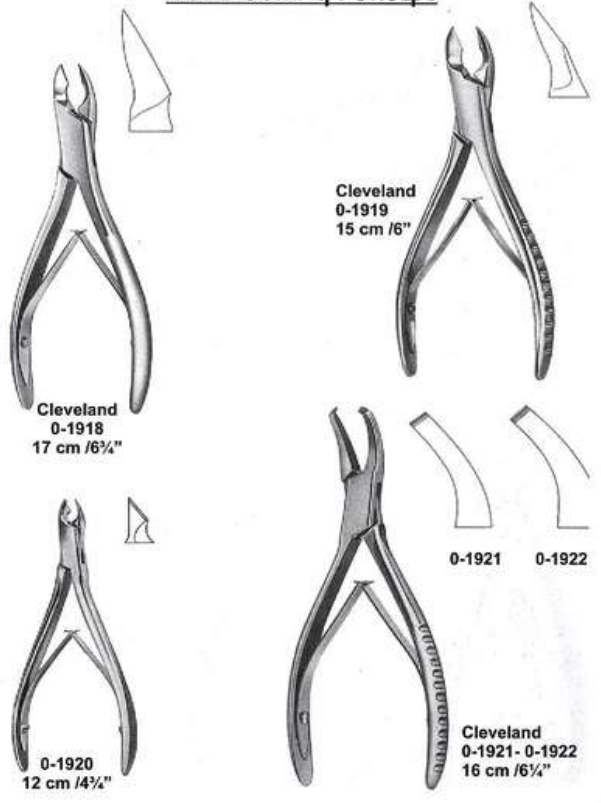

**BONE RONGEUR FORCEPS**

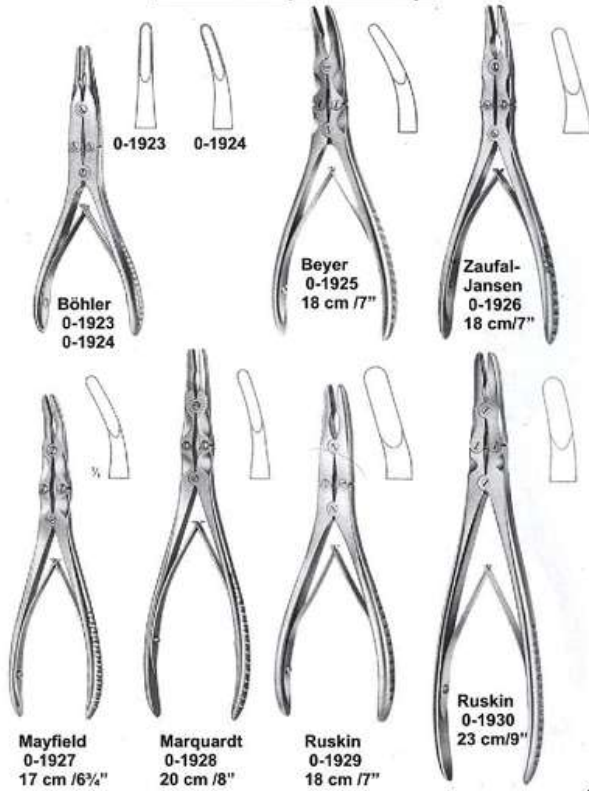

**BONE RONGEUR FORCEPS**

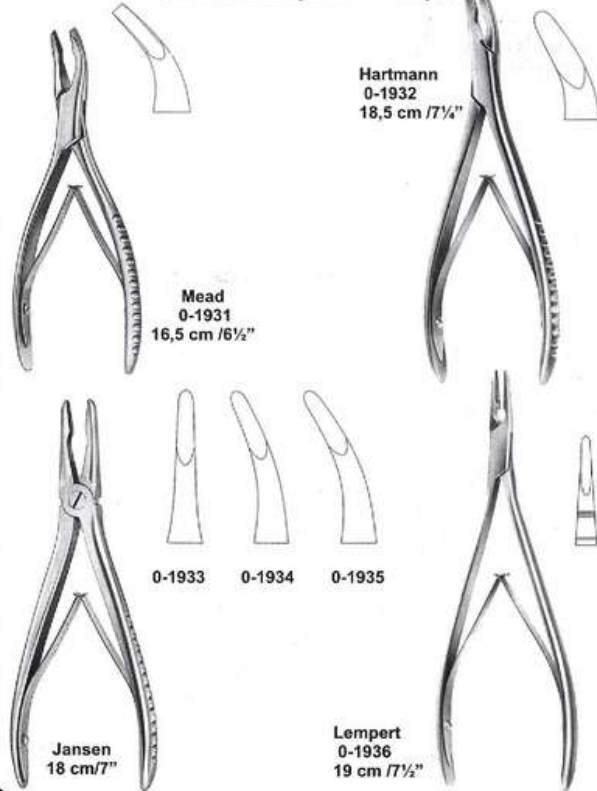

76

**BONE RONGEUR FORCEPS**

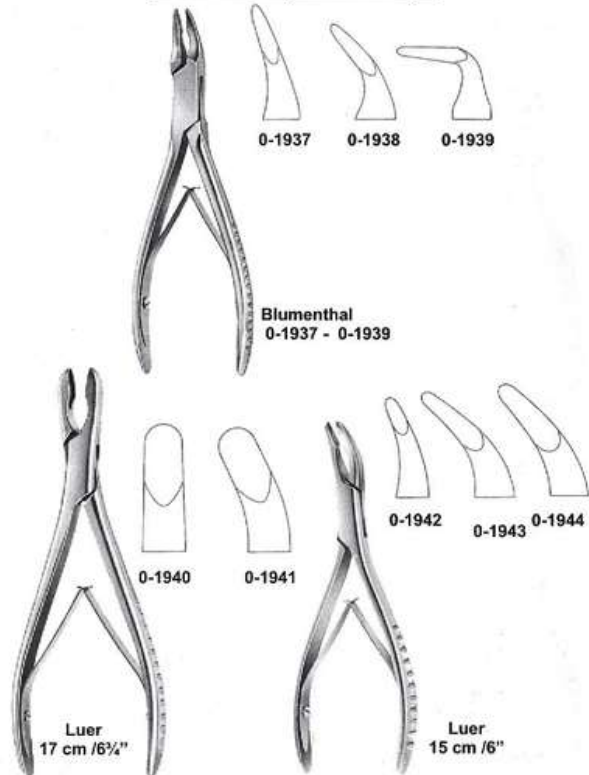

**BONE RONGEUR FORCEPS**

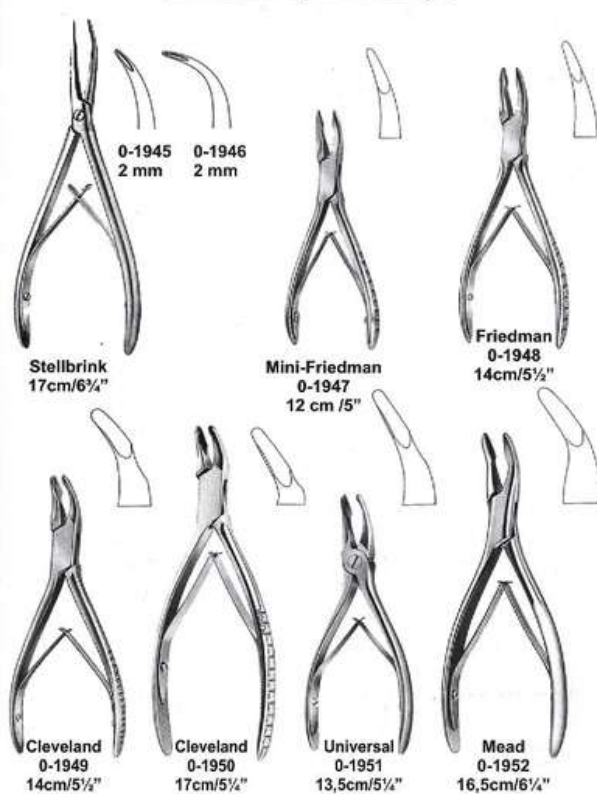

## RASPATOIRES

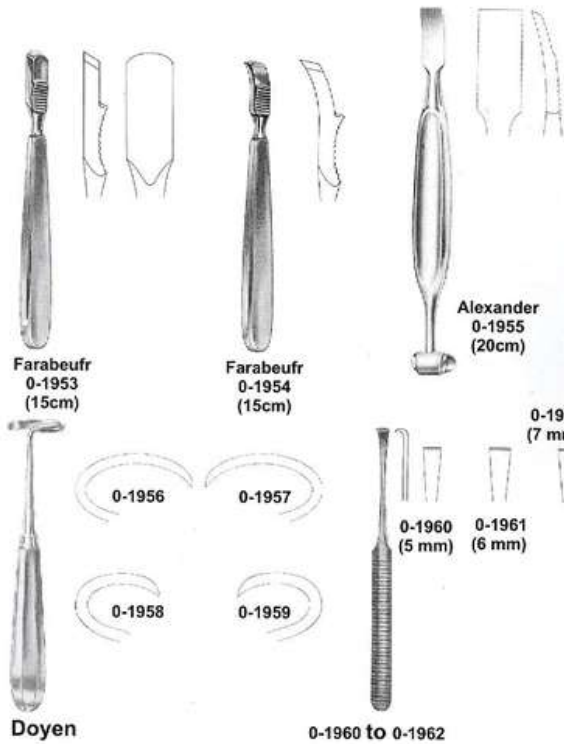

## EXTENSION BOWS BONE WIRE TIGHTENERS

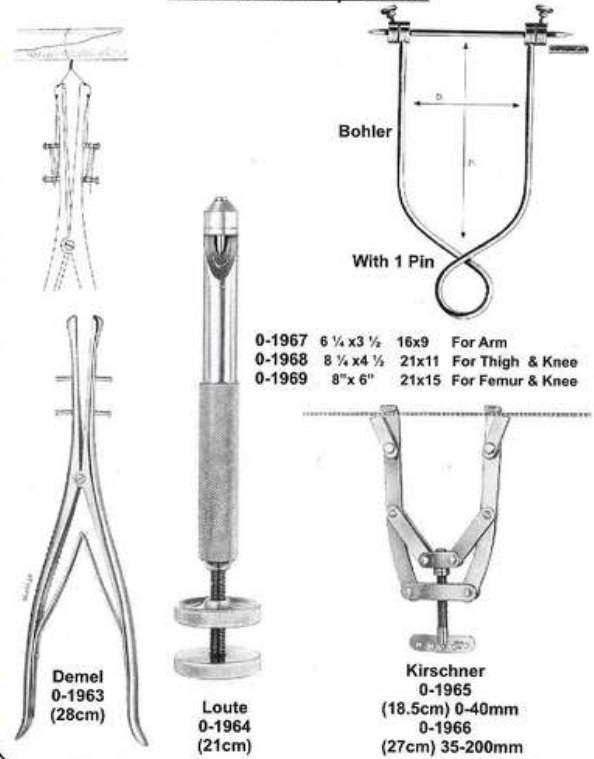

77

## MALLETS



## MALLETS, GOUGES & PERIOSTEAL ELEVATORS

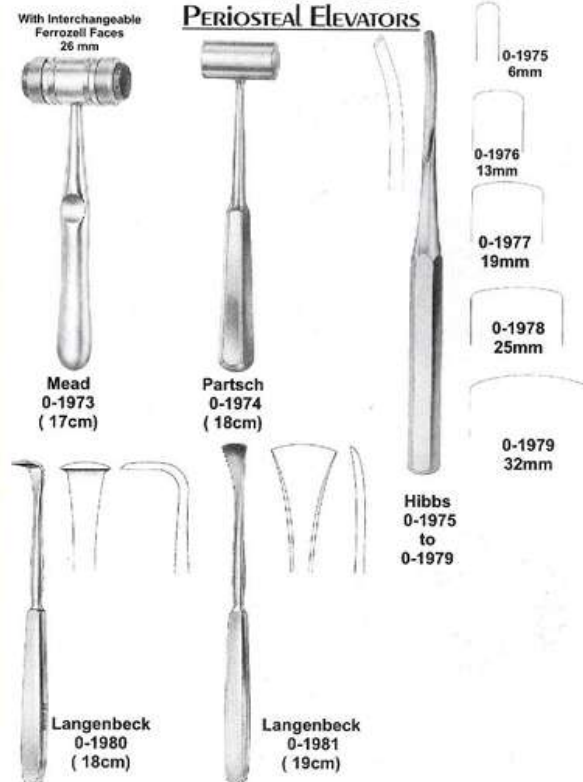



## SURGICAL HOLLOWARE



### Sterilizing Drums

0-1982	8x8 cm
0-1983	12x12 cm
0-1984	16x12 cm
0-1985	19x14 cm
0-1986	19x20 cm
0-1987	24x12 cm
0-1988	24x16 cm
0-1989	24x24 cm
0-1990	29x12 cm
0-1991	29x16 cm
0-1992	29x24 cm
0-1983	34x16 cm
0-1994	34x24 cm
0-1995	39x14 cm
0-1996	39x20 cm
0-1997	39x29 cm

## SURGICAL HOLLOWARE



Wash Basin  
0-1998  
10 cm  
12 cm  
14 cm



Sponge Bowl  
0-1999  
12 cm  
15 cm  
20 cm

Lotion Bowl  
without spout / Lip  
0-2000  
08 cm  
10 cm  
12 cm  
14 cm  
15 cm  
20 cm  
25 cm  
30 cm  
35 cm



78

## SURGICAL HOLLOWARE

Instruments Boiler with Lid  
Perforated internal Tray & Hook  
0-2001  
28x12.5x6.5 cm



Scaler Tray  
0-2003  
19x10x2 cm



Instruments Box  
Perforated  
0-2002  
20x10x4 cm  
24x15x4 cm  
30x15x4 cm

## SURGICAL HOLLOWARE

Electric Sterilizer / Boiler  
Hand Made  
0-2004



20x10x12 cm  
25x12x14 cm  
30x15x15 cm  
35x17x17 cm  
40x20x18 cm  
45x23x19 cm

Non Electric Sterilizer / Boiler  
With Stand / Internal Tray  
0-2005



20x10x6.5 cm  
25x12.5x6.5 cm  
30x15x10 cm  
35x17x6.5 cm  
40x20x10 cm

**SURGICAL HOLLOWARE**



Instruments Tray  
0-2006



Perforated Tray  
0-2007  
20x10x4 cm  
25x12x5 cm  
30x15x5 cm  
35x17x5 cm  
40x20x5 cm



Instruments Tray  
0-2008  
10x15x2.5 cm  
15x20x4 cm  
20x25x4.5 cm  
25x30x5 cm  
30x35x5 cm  
15x30x5 cm  
20x30x5 cm  
23x15x5 cm



Mayo Tray  
Utility Tray  
Dental Tray  
0-2009

**SURGICAL HOLLOWARE**



Instruments Box  
with Cover & Hooks  
0-2010  
17x7x3 cm  
18x8x4 cm  
20x10x4 cm  
23x12x5 cm  
25x12.5x5 cm  
30x15x5 cm  
35x17x5 cm  
40x20x9 cm  
50x20x12 cm



Instruments Box  
with Cover  
0-2011

17x7x3 cm  
18x8x4 cm  
20x10x4 cm  
23x12x5 cm  
25x12.5x5 cm  
30x15x5 cm  
35x17x5 cm  
40x20x9 cm  
50x20x12 cm



Instruments Box  
with lid  
0-2012

**SURGICAL HOLLOWARE**



Kidney Tray  
with Lid  
0-2013  
15 cm  
20 cm  
25 cm  
30 cm



Kidney Tray (Shallow)  
0-2014  
17 cm  
22 cm  
24 cm



Kidney Tray  
(Traditional)  
0-2015  
12 cm  
15 cm  
18 cm  
20 cm  
25 cm  
28 cm  
30 cm

**SURGICAL HOLLOWARE**

Cather Tray  
with lid  
0-2016  
30x8x4 cm  
35x9x4.5 cm  
40x10x5 cm



Instruments Tray  
with lid  
0-2017



10x15x2.5 cm  
15x20x4 cm  
20x25x4.5 cm  
25x30x5 cm  
30x35x5 cm  
15x30x5 cm  
20x30x5 cm  
23x15x5 cm

Instruments Tray  
With Lid  
0-2018



**SURGICAL HOLLOWARE**



Dressing Jarr  
0-2019  
3X3 "  
4X4 "  
4 1/4 "X4 1/4 "  
6X6 "



Dressing Jarr  
0-2020  
3X3 "  
4X4 "  
4 1/4 "X4 1/4 "  
6X6 "



0-2021  
Measuring Jug  
0.25 Ltr  
0.5 Ltr  
1.0 Ltr  
2.0 Ltr



0-2022  
Enema Cane  
Douch Cane / Irrigator



1.0 Ltr  
1.5 Ltr  
2.0 Ltr

0-2023  
Enema Cane  
Douch Cane / Irrigator

**SURGICAL HOLLOWARE**



Funnel  
0-2024  
125x127 mm

Kick Bucket With Trolley  
0-2025  
39x28x18 cm



**SURGICAL HOLLOWARE**



Bedpan Simple pressed Body  
with handle)  
0-2026 for Adult  
0-2027 for Child



Bedpan Slipper Type  
with Cover & handle  
0-2028 for Adult  
0-2029 for Child



0-2030  
Bedpan Round  
with cover & handle



Bedpan Hand Made  
0-2031 for Adult  
0-2032 for Child



All Products Are  
Available In Different  
Sizes

**SURGICAL HOLLOWARE**



Bedpan Perfection Type  
(Seamless)  
0-2033 for Adult  
0-2034 for Child



Bedpan Perfection Type  
0-2035 for Adult  
0-2036 for Child

Urinal Male (Vertical)  
0-2037



Urinal Female  
0-2038

Urinal Male (Horizontal)  
UNICEF  
0-2039



SURGICAL HOLLOWARE



Cotton Holding Jar  
0-2040

All  
Products  
Are  
Available  
In  
Different  
Sizes

5x18 cm  
6.5x20 cm  
8x20 cm  
10x20 cm



Thermometer Jar  
0-2041

0-2042  
Forcep Jar

SURGICAL HOLLOWARE



Dustbin with stand & Cap  
0-2045 6.0 Liter  
0-2046 10 Liter

81

SURGICAL HOLLOWARE



Needle Case Round  
0-2047  
8x2 cm

Needle Case Round  
with cover  
0-2048  
6.5x1.5 mm

Needle Case Rectangle  
0-2049  
70x70x10 mm



Test Tube Rack  
0-2050  
24 tubes  
12 tubes

All  
Products  
Are  
Available  
In  
Different  
Sizes

SURGICAL HOLLOWARE

All  
Products  
Are  
Available  
In  
Different  
Sizes

Gallipots  
0-2051

1 oz  
to  
16 oz

Gallipots with Lid  
0-2052



0-2053  
Spirit lamp  
Double Knot  
4 oz  
6 oz



0-2054  
Spirit lamp  
4 oz  
6 oz



Sputam Cup  
Spitten Mug  
0-2055 10x5 cm



Fetal Scope  
0-2056 15 cm

Medicine Cup  
Iodine Cup  
0-2057  
50/60/70 ml

